

University of Louisville

ThinkIR: The University of Louisville's Institutional Repository

Electronic Theses and Dissertations

5-2015

Role of c-Kit in the growth, migration and differentiation of human cardiac progenitor cells.

Bathri Narayan Vajravelu
University of Louisville

Follow this and additional works at: <https://ir.library.louisville.edu/etd>



Part of the [Biochemistry Commons](#), and the [Molecular Biology Commons](#)

Recommended Citation

Vajravelu, Bathri Narayan, "Role of c-Kit in the growth, migration and differentiation of human cardiac progenitor cells." (2015). *Electronic Theses and Dissertations*. Paper 2076.
<https://doi.org/10.18297/etd/2076>

This Doctoral Dissertation is brought to you for free and open access by ThinkIR: The University of Louisville's Institutional Repository. It has been accepted for inclusion in Electronic Theses and Dissertations by an authorized administrator of ThinkIR: The University of Louisville's Institutional Repository. This title appears here courtesy of the author, who has retained all other copyrights. For more information, please contact thinkir@louisville.edu.

ROLE OF C-KIT IN THE GROWTH, MIGRATION AND DIFFERENTIATION OF
HUMAN CARDIAC PROGENITOR CELLS

By

Bathri Narayan Vajravelu
M.B.B.S., Tamil Nadu Dr. M.G.R. Medical University, 2006
MPH, Western Kentucky University, 2010
M.S., University of Louisville, 2013

A Dissertation
Submitted to the Faculty of the
School of Medicine of the University of Louisville
in Partial Fulfillment of the Requirements
for the Degree of

Doctor of Philosophy in Biochemistry and Molecular Biology

Department of Biochemistry and Molecular Genetics
University of Louisville
Louisville, Kentucky

May 2015

Copyright 2015 by Bathri N. Vajravelu

All rights reserved

ROLE OF C-KIT IN THE GROWTH, MIGRATION AND DIFFERENTIATION OF
HUMAN CARDIAC PROGENITOR CELLS

By

Bathri N. Vajravelu

M.B.B.S., Tamil Nadu Dr. M.G.R. Medical University, 2006

MPH, Western Kentucky University, 2010

M.S., University of Louisville, 2013

A Dissertation Approved on

Apr 27, 2015

by the following Dissertation Committee

Dissertation Director: Dr. Kyung Hong

Dr. Aruni Bhatnagar

Dr. Steven Jones

Dr. Alan Cheng

Dr. Marsha Cole

DEDICATION

This dissertation is dedicated to my mother

Mrs. Rajeswari Vajravelu

who gave me the direction to choose stem cell research.

ஈன்ற பொழுதினும் உனை பெரிதுவக்க நான் முயன்று கொண்டிருக்கையில்
ஆணிவேராய் இருந்த நீ மண் சேர்ந்து விட்டாய்
பலர் வாழ்நாள் நீண்டு வாழ மருத்துவம் பயில சொன்னாய்
உன் வாழ்நாள் அருகில் முடியும் என்று அறியாது நான் இருந்தேன்
நான் சோர்ந்து போகும் போதெல்லாம் தேற்றி விட்டாய்
நீ வீழ்ந்து போகும் போது நான் விழி தேம்பி நின்றேன்
உன்னை தாங்க என் கையில் வலிமை இல்லை
நீ இல்லாத நாட்களை கழிக்க வழி தெரியவில்லை
துன்பமான இவ்வுலகில் எனை ஈன்று
இன்பமான மறு உலகிற்கு நீ விரைந்து சென்றாய்
உன் அருகில் தற்பொழுது நான் இல்லை என்றாலும்
என் அருகில் தயவுசெய்து நீ இருந்துவிடு!

ACKNOWLEDGEMENTS

I am very grateful to my mentor Dr. Kyung Hong for his valuable guidance and patience in teaching me the basics of scientific research and developing my organizational skills. This dissertation would not have been possible without his encouragement and support. I would like to thank my committee members, Dr. Aruni Bhatnagar, Dr. Steven Jones, Dr. Alan Cheng, Dr. Marsha Cole for their valuable guidance and directions in completing this project. I would like to thank my past and present lab members Afsoon Moktar, Tareq Al-maqtari, Pengxiao Cao and Michael Book for being there whenever I needed them. I am thankful to Dr. William Dean and Dr. Jaydev Dholakia for their support and advice. I am thankful to Dr. Marcin Wysoczynski, Dr. Joseph B. Moore IV and Mr. John Zhao for generously sharing the results of their work that is related to my project. I am very thankful to Senthil Muthusamy and Dr. Lakshmanan Annamalai for their friendship, guidance and motivation that extend beyond Baxter II. I am very thankful for my wonderful wife Bhuvaneshwari Bathri Narayan for being my mother in her love and care for me. Thanks to all my friends who stood by me when I was going through any rough phase in my life.

ABSTRACT

ROLE OF C-KIT IN THE GROWTH, MIGRATION AND DIFFERENTIATION OF HUMAN CARDIAC PROGENITOR CELLS

Bathri N. Vajravelu

April 14, 2015

The belief that adult mammalian heart lacks regenerative potential was challenged by the identification of c-kit positive cardiac progenitor cells (CPCs) in the heart. A recent phase I clinical trial (SCIPIO), has shown that autologous c-kit positive CPCs improve cardiac function and quality of life when transplanted into ischemic heart disease patients. c-Kit is a type III receptor tyrosine kinase and a common stem cell antigen. Stem cell factor (SCF) is the only known ligand for c-kit. Although c-kit is extensively used as an invariable marker of resident CPCs and shown to be important in the context of different cell types, there is no information on its role in the regulation of cellular characteristics of CPCs. This led us to hypothesize that c-kit plays a role in the regulation of survival, growth and migration of human CPCs. To test this hypothesis, CPCs were grown under stress conditions (e.g., serum starvation and oxidative stress) in the presence or absence of SCF. The effects of SCF-mediated activation of c-kit on CPC survival/growth were measured using cell viability assay, BrdU labeling and caspase 3/7 activity assay. I observed a statistically significant increase in cell survival with SCF treatment compared to the untreated control when CPCs were subjected to serum depletion. However, SCF treatment did not lead to a

significant increase in cell viability against 2,3-dimethoxy-1,4-naphthoquinone (DMNQ) or hydrogen peroxide (H₂O₂) induced oxidative stress. Furthermore, the pro-survival effect of SCF was augmented by c-kit overexpression and abrogated by co-treatment with imatinib, an inhibitor of c-kit, suggesting that necessity of c-kit activity for the effect of SCF. I then checked if activation of c-kit can promote migration of CPCs. I found that CPCs were highly chemotactic to SCF showing a statistically significant increase in cell migration after SCF treatment. The results of the differentiation study are not convincing and need further experiments to derive a conclusion. We also found that SCF treatment on CPCs activated the phosphoinositide 3-kinase (PI3K) and the mitogen activated protein kinase (MAPK) pathways. With the use of specific inhibitors, we confirmed that the SCF dependent survival and chemotaxis of CPCs are dependent on these two pathways. In conclusion, the results of our experiments suggest that c-kit promotes the survival, growth and migration of CPCs cultured *ex vivo* via the activation of PI3K and MAPK pathways. These results imply that the efficiency of homing of CPCs to the injury site as well as their post-transplantation survival may be improved by modulating the activity of c-kit.

TABLE OF CONTENTS

	PAGE
DEDICATION.....	iii
ACKNOWLEDGEMENTS.....	iv
ABSTRACT.....	v
LIST OF FIGURES.....	ix
CHAPTER	
I. GENERAL INTRODUCTION.....	1
c-Kit Positive Cardiac Progenitor Cells.....	1
Cardiac Progenitor Cell Niches.....	3
Therapeutic Potential of Cardiac Progenitor Cells.....	3
Recent Controversy on CPCs.....	5
Survival of CPCs After Transplantation.....	8
Introduction to c-Kit.....	9
Functional Role of c-Kit.....	10
Steel Factor or the Stem Cell Factor.....	17
c-Kit Receptor Activation, Downregulation & Inhibition..	20
Signal Transduction.....	21
Project Overview.....	29
II. ROLE OF C-KIT IN THE GROWTH, MIGRATION AND DIFFERENTIATION OF HUMAN CARDIAC PROGENITOR CELLS.....	31
Introduction.....	31
Materials and Methods.....	33
Results.....	38

	Discussion.....	56
III.	MOLECULAR PATHWAYS INVOLVED IN SCF-C-KIT MEDIATED HUMAN CARDIAC PROGENITOR CELL SURVIVAL OR GROWTH AND MIGRATION.....	61
	Introduction.....	61
	Materials and Methods.....	66
	Results.....	66
	Discussion.....	73
IV.	Conclusion & Future Directions.....	78
	REFERENCES.....	81
	CURRICULUM VITAE.....	101

LIST OF FIGURES

FIGURE	PAGE
1. Schematic representation of the structure of c-kit.....	16
2. Schematic representation of the structure of SCF.....	19
3. Signal transduction in SCF activated c-kit receptor.....	23
4. Schematic representation of the PI3K-AKT signaling pathway	26
5. Schematic representation of the MEK-ERK signaling pathway	28
6. Schematic representation of the project.....	30
7. Activation of c-kit by SCF in human c-kit+ CPCs.....	40
8. c-Kit activation promotes growth of human c-kit+ CPCs under serum starvation.....	41
9. c-Kit over expression further increases CPC survival under serum starvation.....	43
10. c-Kit activation does not rescue CPCs from oxidative stress.....	45
11. c-Kit activation induces proliferation and decreases apoptotic cell death in CPCs.....	47
12. c-Kit activation promotes migration of CPCs.....	49
13. c-Kit activation does not play a role in the differentiation of CPCs.....	53
14. c-Kit activation does not affect the clonogenicity and pluripotency of CPCs.....	55
15. Schematic representation of chapter III.....	65
16. Schematic representation of chapter III experimental approach.....	68

17. SCF dependent c-kit stimulation activates the PI3K-AKT and MEK-ERK1/2 pathways.....	69
18. Inhibition of the PI3K-AKT and MEK-ERK1/2 pathways with the inhibitors, Wortmannin and PD98059.....	70
19. Pro-survival and chemotactic effect of SCF was abolished by pre-treatment with inhibitors.....	71

CHAPTER I

GENERAL INTRODUCTION

The report presented in this dissertation is a summary of my research on the role of c-kit in the growth, survival, migration and differentiation of human cardiac progenitor cells (CPCs). For a novice reader, it is essential to have an understanding about the cardiac progenitor cells, c-kit, the scientific evidences that guided the design of my study and the rationale behind our hypotheses. For this purpose, the first chapter is dedicated to educate the reader on the available information about CPCs, c-kit and its most common biological functions that are relevant to the hypotheses of this project. I believe the results of this study will bring in new ideas and further research in establishing the critical role of c-kit and CPCs in cardiac regenerative therapy.

c-Kit Positive Cardiac Progenitor Cells:

Mammalian heart was considered as a terminally differentiated organ for a long time until the beginning of this century when several studies challenged the notion by reporting the renewal of cardiomyocytes [1-3]. These studies established the fact that adult mammalian heart has the inherent capacity to regenerate although to a limited extent. The interesting discovery about the regenerative potential of the heart initiated a number of studies that investigated the presence of resident stem/progenitor cells in the heart that contribute to tissue maintenance and repair [4-6]. The results of these studies indicated that heart has a reserve of its own primitive

cell population that could contribute to the regeneration process upon injury. These stem cell populations were identified based on their expression of common stem cell antigens, such as c-kit [4, 7, 8] and Sca-1[9-11] or on their ability to efflux a fluorescent dye, Hoechst 33342 (“side population”) [12-14] or to form spherical bodies (“cardiospheres”) under a specific culture condition [15-17] or by the presence of a progenitor transcription factor islet-1(Is11⁺ CPCs) [18, 19]. Among the above list of primitive cell populations, the c-kit positive CPCs were chosen as a subject for this study because of its proven efficacy in myocardial regeneration in animals [4, 20] and in humans [6].

A report by Beltrami *et al.* in 2003 was the first to demonstrate that heart harbors a group of cells with properties of cardiac progenitor cells (CPCs) identified by their expression of the stem cell marker, c-kit [4]. When these c-kit⁺ cells were isolated and grown in culture, they were self-renewing, clonogenic, and multipotent, being able to differentiate into cardiomyocytes, smooth muscle and endothelial cells both *in vitro* and *in vivo* confirming their stemness. Upon isolation and analysis, they were found to be negative for the panleukocyte marker CD45 and hematopoietic marker CD34 indicating they did not originate from the bone marrow [4]. These cells expressed Ki67, a cell cycle marker indicating that these are proliferating cells and they also expressed certain cardiac transcription factors like GATA4, NKX2.5, MEF2 suggesting their cardiomyogenic commitment. However, these were found to be negative for mature myocyte, endothelial, smooth muscle cell and fibroblast lineage markers and thus were characterized as lineage negative (Lin⁻).

Cardiac Progenitor Cell Niches:

CPCs are found to be situated in specialized niches in the myocardium mostly in the apex and atrium of the heart and are less abundant at the base and in the ventricle [21]. They are connected to the surrounding cardiac cells through gap and adherens junctions [22]. These junctions facilitate communication between the cells and also anchor the CPCs to the surrounding microenvironment [23]. Sanada *et al* recently reported that based on the oxygen tension, the niches can be either hypoxic or normoxic [24]. While the normoxic niches contain actively dividing functional CPCs, the hypoxic niches are a storehouse of quiescent, non-dividing CPCs. The study found that the number of hypoxic non-dividing CPCs increase with aging, indicating that the aged heart has a greater accumulation of non-functional CPCs that do not participate in tissue repair. Interestingly, c-kit activation was found to reverse this balance and enrich the senescent heart with younger, actively dividing CPCs. When the authors injected SCF in the heart of aged mice they found a significant increase in the number of functional CPCs with a concomitant reduction in the number of quiescent CPCs. This indicates that SCF induced c-kit activation repopulated the senescent heart with functional CPCs similar to younger hearts. The study also established that these newly activated CPCs are derived from the quiescent CPC pool further supporting the importance of c-kit activation in maintaining functional CPC niches in the heart and its contribution to myocardial rejuvenation.

Therapeutic Potential of Cardiac Progenitor Cells:

Functionally, injecting these cells (marked by EGFP expression) in the border zone of infarcted hearts in rats significantly regenerated the myocardium when compared to the control animals. The regenerated myocardium was found to have

significant number of myocytes that were expressing EGFP confirming their origin from the injected cells [4]. Similarly, another study found that intracoronary injection of these cells in a rat model can reduce left ventricular remodeling after MI and also the infarct size by 29% compared to the control rats [25] adding more support to the role of these cells in cardiac regeneration. Although the mechanism by which these cells contribute to the regeneration process is still under investigation, co-culturing these CPCs with mature cardiomyocytes was found to induce their own differentiation to cardiomyocyte and also promoted the survival of the co-cultured cardiomyocytes [26] substantiating that these cells are essential for cardiomyocyte survival and regeneration. In summary, all the above findings strongly suggest that the c-kit positive cardiac progenitor cells have the capacity to differentiate in to cardiac cells and can regenerate the infarcted myocardium.

Supported by the encouraging role of c-kit⁺ CPCs in cardiac regeneration in animal models, the therapeutic transplantation of these cells were tested in a phase I clinical trial “SCIPIO” (Stem Cell Infusion in Patients with Ischemic Cardiomyopathy) [6]. The study was conducted by the group directed by Dr. Roberto Bolli, Division of Cardiovascular Medicine in the University of Louisville, KY on patients suffering from ischemic cardiomyopathy. In this trial, CPCs were isolated from the atrial appendages of patients with heart failure secondary to myocardial infarction when they were undergoing coronary artery bypass grafting (CABG). The isolated cells were expanded and autologous transplantation of CPCs was performed via an intracoronary injection. The initial results of this clinical trial confirmed that autologous transplantation of c-kit⁺ CPCs can significantly improve the heart function and the quality of life in patients suffering from ischemic cardiomyopathy. The left ventricular ejection fraction (LVEF) which is a marker of LV function

improved by nearly 8% within 4 months after injecting these cells whereas there was no change in the LVEF in the untreated control patients . In the same period, the mean infarct size reduced by 24% after injecting these CPCs in the patients [6]. A more important finding of the study is that the regenerative effects of CPC transplantation were sustained in a majority of the treated patients a year after transplantation. The study reported that at the end of one year after CPC transplantation, the infarct size in the treated patients reduced significantly to about 30% lesser than the baseline, confirmed by an MRI. The results of this study clearly demonstrate the utility of c-kit⁺ CPCs in cardiac regeneration in human beings.

Recent Controversy on CPCs:

Some of the studies published recently questioned the myogenic potential and the importance of c-kit⁺ CPCs in the regeneration of injured myocardium. For example, Berlo *et al* [27] used the Cre-lox based lineage tracing technique to analyze the fate of the c-kit⁺ cells. The results of this study demonstrated that although c-kit⁺ progenitors generate significant amount of endothelial cells, they contribute to less than 1% of the cardiomyocytes in the developing, adult and injured heart, questioning their functional importance. However the authors failed to address the caveats that are associated with their experimental design. For instance, the recombination efficiency in c-kit⁺ CPCs is largely ignored. Estimating the contribution of the c-kit⁺ CPCs to myogenesis is completely dependent on the expression of the reporter gene that will be turned on after effective recombination. Hence without this data, the results derived are largely inconclusive. Furthermore, no control was provided to show that the c-kit expression in the recombined cells is identical to the WT or the unmodified gene. Also Cre expression has been shown to be toxic to the cells [28] and the authors

failed to add information about the toxicity of Cre in their system. Without experimentally addressing these critical issues, the results obtained through this study by Berlo *et al* certainly do not support the conclusion that c-kit⁺ CPCs are not functionally important. Another study by Cheng *et al* [29] depleted the c-kit fraction of the cardiosphere derived cells (CDCs, another heart derived progenitor cell population) and demonstrated that the functional benefits of CDCs in an animal model of myocardial infarction is not compromised after depleting the c-kit⁺ cells, raising concerns about the relevance of resident c-kit⁺ CPCs in myocardial regeneration. The authors demonstrated that attenuation of left ventricular remodeling was greater in CD90 depleted CDCs and in double depleted (CD90 and c-kit depleted) population than the unsorted CDCs, while the c-kit depleted CDCs were similar to the unsorted CDC group. The authors also mentioned that the CDCs contained only a small fraction of c-kit⁺ cells (0.3% to 7.2%) and the percentage was highly variable from patient to patient. On the other hand, the CD90 expression varied broadly from 0.2% to 94.6% indicating that the CDCs contain a very high proportion of CD90⁺ cells and a minor population of c-kit⁺ cells. The results also showed that functionally, the unsorted CDCs are similar to the c-kit depleted CDCs and the CD90 depleted fraction in all cases is similar to the double depleted fraction. This further corroborates that the c-kit⁺ cells constitute a minor fraction of CDCs and therefore the results of this study cannot stand alone to invalidate the role of c-kit⁺ CPCs in cardioprotection.

In contrast, diametrically opposed results have been reported by other studies that support the notion that c-kit⁺ CPCs are indispensable for remuscularization of the heart [25, 30, 31]. For instance, in an animal model of isoproterenol (ISO) induced MI, Ellison and colleagues [20] have shown that the endogenous CPCs are crucial and are sufficient to regenerate the myocardium after injury. The authors found 88% of

CPCs were BrdU+ at day 3 after MI and were maintained significantly higher up to 28 days when compared to the uninjured control rats. Many of the c-kit+ CPCs expressed GATA4 and NKX2.5 indicating their commitment to cardiovascular lineage. They also found that starting at day 3, BrdU+ Ki67+ cardiomyocytes increased gradually in size and number from day 3 to day 28 suggesting active myogenesis. Using a tamoxifen inducible GFP expression system the authors demonstrated that the pre-existing cardiomyocytes and the bone marrow cells do not contribute to the myogenesis in the injured heart. To confirm the newly formed cardiomyocytes are from the endogenous CPCs, they used lentivirus to express YFP in the c-kit expressing cells of the heart and found that a significant proportion of cardiomyocytes originated from the CPCs identified by their YFP expression.

To further ascertain that the CPCs are sufficient for myocardial regeneration, the authors eliminated the proliferating CPCs with the anti-mitotic agent 5-Fluouracil (5-FU). Next, they injected ISO followed by the injection of GFP+ CPCs or GFP+ cardiac fibroblasts in the tail vein. Only the CPCs injected group recovered from ISO induced cardiac failure at 2 months after injection. To confirm if the recovery was indeed because of the injected CPCs, the authors induced suicide of the injected cells that co expressed herpes simplex virus thymidine kinase (HSVTK) along with GFP by administering ganciclovir. Selective suicide of the transplanted CPCs recapitulated the cardiac failure phenotype confirming that the regeneration was exclusively due to the injected c-kit+ CPCs. Among the injected GFP+ CPCs, around 68% formed cardiomyocytes while they also observed 13% of smooth muscle cells and 17% of endothelial cells originating from the injected cells. More interestingly, the transplanted GFP+ CPCs upon reisolation and testing were found to retain their stem cell properties. Taken together, these results unequivocally support the conclusion that

the endogenous c-kit⁺ CPCs are sufficient and are essential for the structural and functional regeneration of the infarcted heart.

Survival of CPCs After Transplantation:

Cellular therapy for the regeneration of ischemic myocardium is a promising option but several studies identified poor survival of the transplanted cells limiting the treatment outcome. For example, in a study conducted by Hayashi *et al*, upon injecting the bone marrow cells in a rat model of acute MI, the investigators found that only 6% of the delivered cells survived at the end of 3 days [32]. Similarly, in a porcine model of MI, only 5% of the mesenchymal stem cells that were delivered via an intracoronary infusion survived at the end of 14 days after transplantation [33]. Substantiating the findings of the above studies, Hong *et al* have recently shown that when CPCs were delivered via the intracoronary route after inducing MI in a mouse model, only 5% of the injected cells survived at the end of day 1 and only 1% of the injected cells were detected at the end of 35 days in the heart [34]. The findings of the above studies indicate that regardless of the cell source, it is critical to improve the survival of the transplanted cells to achieve successful regeneration of the infarcted myocardium. Better survival of the grafted cells can be accomplished by improving the homing capacity of the cells or its growth or by reducing the death of the transplanted cells. For this purpose, to achieve significant remuscularization of the ischemic myocardium with CPC based therapy, it is imperative to identify key regulators that can influence the cellular properties of CPCs.

The search guided our laboratory to investigate if the stem cell marker c-kit can be the key protein regulating the growth, survival, migration and differentiation of CPCs because of the well-established mitogenic, chemotactic and pro-survival effects

of this protein in various cell types. Although c-kit so far has been only used as a surface antigen for identifying CPCs, it has been recognized to play a critical role in regulating survival, proliferation, differentiation, migration and engraftment of mast cells [35], melanocytes [36, 37], germ cells [38, 39] and hematopoietic stem cells [40]. A description on the role of c-kit in some of the above cell types is discussed later in this manuscript. In spite of an established role of c-kit in mediating the survival and migration benefits in a wide variety of cell types, to my knowledge, no studies so far have explored the role of c-kit in the regulation of cellular characteristics in CPCs. This directed us to design the study presented here in which I hypothesized that c-kit plays a role in the survival, growth, migration and differentiation of CPCs. To test this hypothesis, I measured the effect of SCF mediated activation of c-kit on the survival, growth, migration and differentiation of the CPCs and analyzed the mechanism through which these effects are mediated.

Before discussing the experimental results on testing the effect of c-kit activation on the growth, survival, migration and differentiation of CPCs, it is essential to know the basic information about the protein c-kit and its ligand, the stem cell factor or SCF. A short description about the two proteins is given below.

Introduction to c-Kit:

Cellular Kit (*c-kit*) (also known as CD117 or stem cell factor receptor) was discovered in the year 1986 as the cellular homolog of the viral oncogene v-kit. It was identified to be the transforming gene of the Hardy-Zuckerman 4 feline sarcoma virus and hence named “kit”, an abbreviation for “kitten” [41]. The gene encodes a 145 kDa transmembrane glycoprotein that belongs to type-III receptor tyrosine kinase (RTK) family, which includes platelet derived growth factor receptor (PDGFR) and

macrophage colony stimulating factor 1 receptor (CSF-1) [41-43]. Soon after the discovery of c-kit, based on the phenotype of c-kit mutants, it was found that it is allelic with the dominant white spotting locus (*W*) of mice [44]. Similar phenotype was also found in the mice with mutation in the Steel (*Sl*) locus leading to the discovery of the only known ligand for c-kit called the steel factor or the stem cell factor (SCF), the product of *Sl* locus [45, 46].

The c-kit protein has approximately 976 amino acids and the core protein is around 110 kDa in molecular weight. The protein undergoes N-linked glycosylation after translation increasing the weight of the mature protein to approximately 145 kDa. Similar to other type III RTKs, the protein has five extracellular immunoglobulin (Ig) like domains followed by a single transmembrane helix and a short cytoplasmic transmembrane domain (Figure 1). The intracellular part of the protein has two kinase domains separated by a short kinase insert and ends in a carboxy terminus [41]. The c-kit gene was found to be located in the chromosome 4q11 in humans. It has 21 exons covering around 34 kb of DNA [41, 47].

Functional Role of c-Kit:

The idea of testing c-kit in the regulation of the growth, survival, migration and differentiation of CPCs is supported by extensive evidences that are available on this well characterized RTK. Besides being used as a stem cell marker, it is a proto-oncogene and activating mutations in c-kit gene are frequently associated with various types of tumors, such as mast cell tumors, gastrointestinal stromal tumors (GIST), and leukemia [48-50]. In addition to its role as an oncogene, this protein is critical to maintain normal hematopoiesis [40, 51], pigmentation [36, 52], gametogenesis [53, 54], immune response [55, 56], intestinal motility [57, 58], vasculogenesis [59], lung

compliance [60, 61], brain development [62], etc. Although it is beyond the focus of this manuscript to explain all the roles played by c-kit in detail, a brief description of few of them is given below. These reports on the cellular functions of c-kit directed us to test if the activation of c-kit can influence specific cellular properties and pathways in CPCs.

Role of c-Kit in Melanocytes:

c-Kit was originally identified when scientists attempted to find the key molecule that caused white spotting in mice. It was found to be due to a defective migration in melanocytes caused by a loss of function mutation in c-kit or its ligand SCF [47, 63]. Since then, the role of c-kit and SCF in the development, survival and migration of melanocytes has been extensively studied. For example, Luo *et al* have shown that SCF dependent activation of c-kit in cultured melanocytes induces the transcription of tyrosinase gene which is involved in melanogenesis [64]. Studies on the expression patterns of c-kit among different species have indicated that melanocytes are dependent on the activation of c-kit receptor for the migration of its precursors and also for their proliferation and survival [65]. It is interesting to note that the neural crest cells which are the precursors of melanocytes were found to express c-kit as early as embryonic day 9.5 in the head. These precursors then migrate towards the eyes, inner ears and into the second brachial arch [66, 67]. When there is a mutation in c-kit gene, this migration of melanocyte precursors is blocked and they undergo apoptosis resulting in depigmented patches. Study on mouse hair follicle (HF) melanocytes showed that the proliferation of these melanocytes is dependent on c-kit activation [36, 68, 69]. Immunohistochemical analysis of HF melanocytes for Ki-67 and c-kit revealed that only the c-kit expressing subset was actively

proliferating. SCF overexpression in mice significantly increased this actively dividing subset of melanocytes and using a c-kit blocking antibody significantly reduced the number of proliferating HF melanocytes indicating that the mitogenic effect observed was indeed mediated through the activation of c-kit [36]. Taken together, these results indicate that c-kit is an indispensable regulator of melanocyte biology by acting as a mitogen, pro-migratory and pro-survival agent.

Role of c-Kit in Mast Cells:

The role of c-kit in regulating the cellular characteristics of mast cells has been extensively studied. c-Kit has been reported as the key molecule regulating the proliferation, survival, migration, differentiation and secretory functions of mast cells. Mast cells are one of the cell types that maintain c-kit expression after maturation, in addition to the dendritic cells and natural killer cells. Mice with c-kit mutation (W/W^v) were found to have profound mast cell deficiency [70] indicating the critical function of c-kit in mast cell development. Published studies have shown that withdrawing SCF from the media in which mast cells are grown induce apoptosis within 48 hours, identified by DNA fragmentation. Replenishing the media with SCF in the same system could rescue the dying cells demonstrating the anti-apoptotic role of c-kit activation [71]. The mitogenic role of c-kit activation is well established in the bone marrow derived mast cells (BMMC) from mice. It was shown that upon activation of c-kit with SCF, BMMC doubled in number within 48 hours of incubation with the growth factor and the effect was further enhanced by the inclusion of serum [35]. In addition, the same group reported that SCF treatment is required for the BMMCs to enter cell cycle and its availability in the media is critical for the cells to complete the cell cycle and survive [35]. Interestingly, along with the other growth factor IL-3,

SCF could promote the differentiation of pro-mastocyte to mast cells [72]. c-Kit activation was found to promote the migration and mediator release by cutaneous and lung mast cells [73, 74]. Migration of mast cells along a gradient of SCF has been shown to be essential in regulating the mast cell biology [74]. In addition to its pro-survival, mitogenic and chemotactic effects, SCF dependent c-kit stimulation in mast cells was found to cause degranulation and cytokine release. For example, it was shown that c-kit activation could enhance IgE dependent histamine and leukotriene C4 release from human lung mast cells [73] and histamine and prostaglandin release from human cutaneous mast cells [75]. When combined with the results on the role of c-kit in melanocytes, it is clear that c-kit has similar roles in different cell types, acting as a pro-survival, pro-growth and a chemotactic agent.

Role of c-Kit in Hematopoietic Cells:

SCF-c-kit axis has an essential role in maintaining normal hematopoiesis. Hematopoietic cells are found to express c-kit as early as day 8 post-gestation in the mouse embryonic yolk sac. The expression increases until day 15 post-gestation and then gradually decreases [76]. Any aberration in the normal expression of c-kit in the embryonic stage due to a homozygous c-kit mutation is lethal in mice due to severe anemia [77-79]. Studies have shown that transplanting the bone marrow of c-kit mutant white spotted (W/W^l mutant) mice could not replenish cellularity in irradiated hosts confirming that c-kit is essential for normal hematopoiesis [80]. The bone marrow of these mutants were found to have significantly lesser colony forming units spleen (CFU-S), colony forming unit erythroid (CFU-E) and colony forming unit-granulocyte-macrophage (CFU-GM) when compared to their control littermates thereby affecting their capacity to reconstitute the bone marrow cellularity upon

transplantation into the hosts [81-84]. SCF-c-kit signaling plays a vital role in the development and function of both hematopoietic stem/progenitor cells as well as mature cells. For example, it was found that c-kit activation was able to promote the proliferation and survival of hematopoietic stem cells (HSCs) [85]. In a study by Leary *et al* SCF in combination with IL-3 was able to shorten the G₀ phase of the HSCs and drive them to enter the cell cycle, suggesting a mitogenic role for c-kit in HSCs [86]. Furthermore, activation of the c-kit receptor by SCF treatment in an enriched population of long term repopulating HSCs has been shown to significantly increase its survival compared to the cells grown in the medium without SCF [85]. Interestingly, SCF was found to have a synergistic effect with other cytokines like erythropoietin (Epo), granulocyte colony stimulating factor (G-CSF), granulocyte macrophage colony stimulating factor (GM-CSF) and could promote the proliferation as well as the colony size of blood forming unit – erythroid (BFU-E), CFU-GM and colony forming unit - granulocyte, erythrocyte, monocyte, megakaryocyte (CFU-GEMM) [87-89]. Besides playing a crucial role in the maintenance and regeneration of HSCs, c-kit also plays a role in the interaction of HSCs with the niche cells like the endothelial cells and the stromal cells in the bone marrow. This interaction is essential for the motility, survival and proliferation of HSCs, as the bone marrow stromal cells and endothelial cells are an endogenous source of the kit ligand, SCF [90]. In addition to its role in steady state conditions, many studies have highlighted the function of c-kit in the hematopoietic compartment under conditions of stress like ischemic cardiac injury. For example, Fazel *et al* have highlighted that there is an increase in the myocardial expression of SCF after ischemic cardiac injury which mobilizes and recruits c-kit⁺ hematopoietic progenitor cells to the site of injury and contribute to regeneration. In the same model, deletion of c-kit was found to cause cardiac failure

after the ischemic insult which could be rescued by transplantation of wild type bone marrow [91] indicating the critical role of SCF-c-kit signaling in cardiac regeneration. In summary, these results strongly suggest that the SCF-c-kit axis is an essential component of the hematopoietic compartment and is crucial for the growth, survival and migration of the hematopoietic cells under normal and also in conditions of stress.

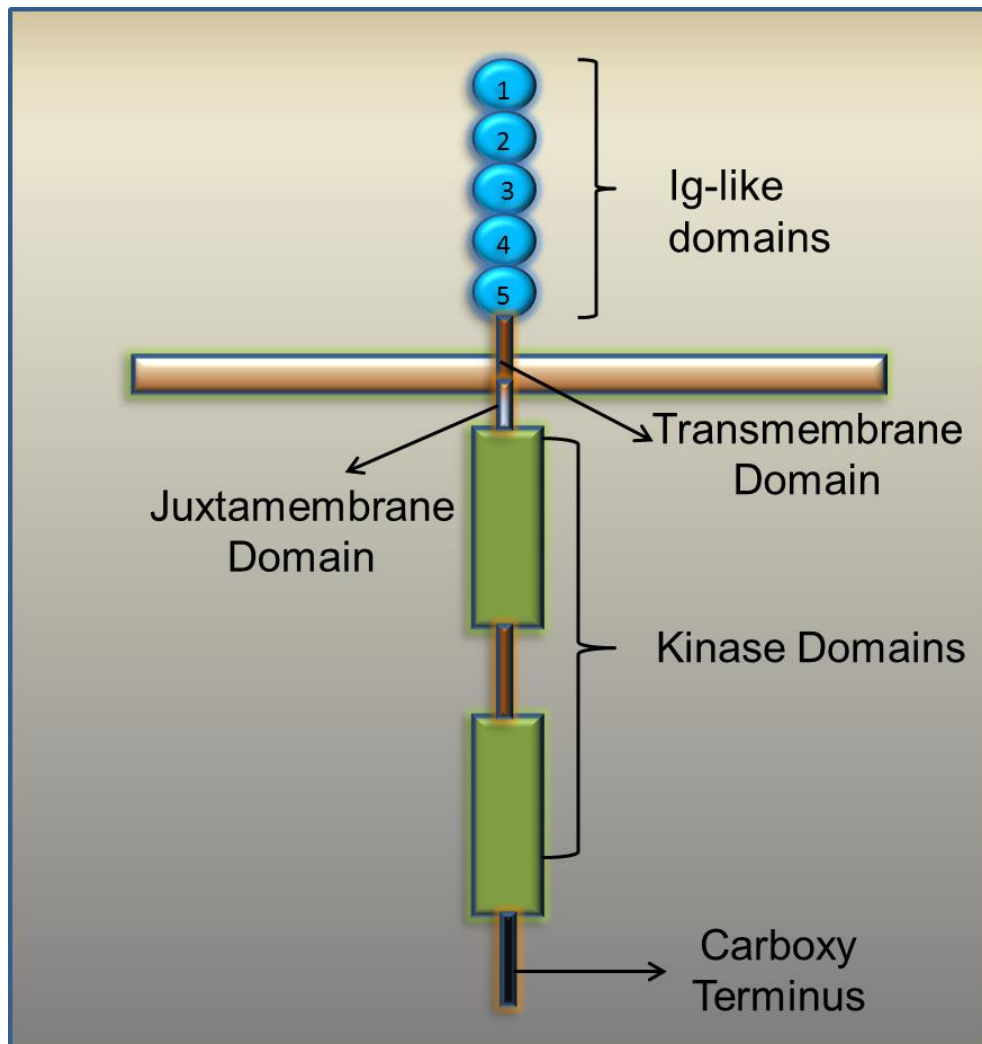

Figure 1: **Schematic representation of the structure of c-kit:** The type III receptor tyrosine kinase has five extracellular Ig like domains, followed by a short transmembrane domain. The intracellular region has two kinase domain separated by a short kinase insert and ends in a carboxy terminus.

Steel Factor or the Stem Cell Factor:

Stem cell factor (SCF), also known as steel factor or kit ligand is the only known ligand for c-kit. The gene encoding SCF is on chromosome 12 in humans and has 9 exons [92, 93]. The protein exists as a membrane bound isoform and a soluble isoform (Figure 2). The two isoforms differ in the presence or absence of exon 6 which encodes a proteolytic cleavage site. Both isoforms when produced are attached to the cellular membrane. The membrane bound isoform has 220 amino acids and the soluble isoform has 248 amino acids [94]. The soluble isoform has exon 6 containing the cleavage site and hence gets cleaved by several proteases like matrix metalloproteases (MMPs), chymase-1 as well as ADAM family proteases to yield a shorter 165 amino acid containing soluble SCF [95-97]. Both the isoforms are biologically active; however, there are significant differences in the intensity and duration of c-kit activation induced by these isoforms [98]. When the cells were treated with soluble SCF, they were found to induce rapid internalization and degradation of the c-kit receptor whereas the membrane bound isoform was found to cause a much prolonged activation of the c-kit receptor and delay the receptor internalization and degradation [99]. It is well known that certain cells like the endothelial cells, fibroblasts and bone marrow stromal cells express SCF which is involved in regulating proliferation, survival, migration and differentiation of its own or the surrounding c-kit positive cells [46, 94, 100]. The regulation of SCF expression is found to be very less understood. Studies have shown that conditions like hypoxia and myocardial infarction can cause an increase in SCF expression [91, 101, 102]. Moreover, exposure to UVB light and follicle stimulating hormone (FSH) treatment were also found to have a similar effect [103, 104]. It is also regulated by post-

translational modification as the protein was found to undergo both N-linked and O-linked glycosylation [105].

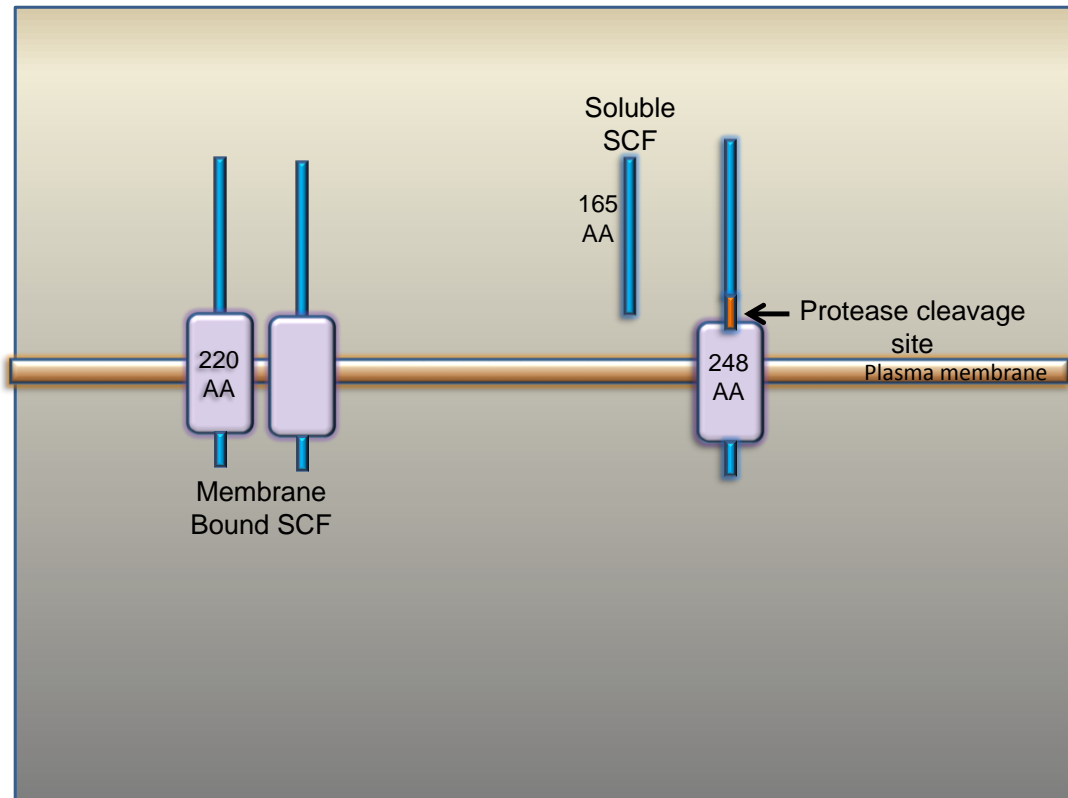

Figure 2: **Schematic representation of the structure of SCF:** The ligand for c-kit, SCF has two isoforms; the membrane bound and the soluble isoform. Both are synthesized as a membrane bound form but the longer transcript gets cleaved by proteases due to the presence of the cleavage site, producing soluble SCF.

c-Kit Receptor Activation, Downregulation & Inhibition:

Similar to other growth receptors like PDGFR and EGFR, c-kit dimerizes upon ligand binding causing autophosphorylation of its tyrosine residues resulting in receptor activation [106]. The extra cellular immunoglobulin (Ig) like domain is critical for ligand binding and dimerization. The ligand SCF binds to adjacent c-kit receptors at the first three Ig like domains inducing a conformational change in the Ig like domains 4 and 5 thereby bringing adjacent c-kit monomers in close proximity. When the receptor is inactive, the juxtamembrane domain interacts with the kinase domain and inhibits its enzyme activity [106-108]. However, upon ligand stimulation and dimerization, specific tyrosine residues (Tyr-568 and Tyr-570) in the juxtamembrane domain get phosphorylated causing a conformational change releasing its inhibitory configuration on the kinase domain. Upon resuming the enzyme activity, the kinase domain phosphorylates other tyrosine residues (autophosphorylation) resulting in receptor activation [108, 109].

Down regulation of c-kit activity can occur through three main processes 1) Receptor internalization and degradation [110], 2) Negative regulation by protein kinase C [111], 3) Tyrosine dephosphorylation by phosphatases [112].

Pharmacological or antibody mediated inhibition of c-kit is widely used to study the role of this protein in mediating cellular responses. For this study, I used the drug Imatinib mesylate (STI571 or Gleevec) to inhibit c-kit activation and to confirm its function in regulating the cellular properties of CPCs. Imatinib was originally derived from a lead compound discovered to inhibit protein kinase C [113]. Drug optimizing experiments revealed that the inclusion of an amide group in the phenyl ring of the lead compound made it an effective inhibitor of the constitutively active tyrosine kinase BCR-ABL which is associated with chronic myeloid leukemia [114].

In vitro screening experiments against a panel of related tyrosine kinases highlighted that this compound is also effective in the inhibition of two other tyrosine kinases, namely platelet derived growth factor receptor (PDGFR) and c-kit [115]. Since then, the compound is widely used in the treatment of cancers related to the expression and over activity of these tyrosine kinases.

Mechanistically, imatinib inhibits the function of its target tyrosine kinases by blocking the transfer of phosphate from ATP to the tyrosine residues on the enzyme substrates. It does this by binding to a specific region in the activation site of the enzyme that is involved in phosphoryl transfer. This binding locks the enzyme in an inactive confirmation and hence the loss of kinase activity [114].

As imatinib is not a specific inhibitor of c-kit and it also inhibits PDGFR that is expressed in cardiac cells, using this pharmacological agent in my experiments to inhibit c-kit could create a concern about the specificity of the inhibitor. I excluded this limitation by using serum free medium for my experiments which does not contain the ligand for PDGFR.

Signal Transduction:

In this study, I have also tested the activation of downstream signaling pathways upon SCF dependent c-kit stimulation. Although my analysis was only restricted to the activation of only the PI3K-AKT and MEK-ERK pathways, activation of c-kit can lead to the recruitment and subsequent activation of a number of downstream mediators (e.g., Grb2, PLD, p38 MAPK, SFK and PLC γ) [116-118]. Figure 3 shows an overview of these signaling molecules that are activated upon c-kit stimulation. It is important to remember that SCF-dependent activation of c-kit can lead to the activation of more than one of these pathways. The combination of

pathways activated and its downstream effects may differ depending on the cell type and species. A short description on the PI3K-AKT and MAPK pathways is given below as it is relevant to this study.

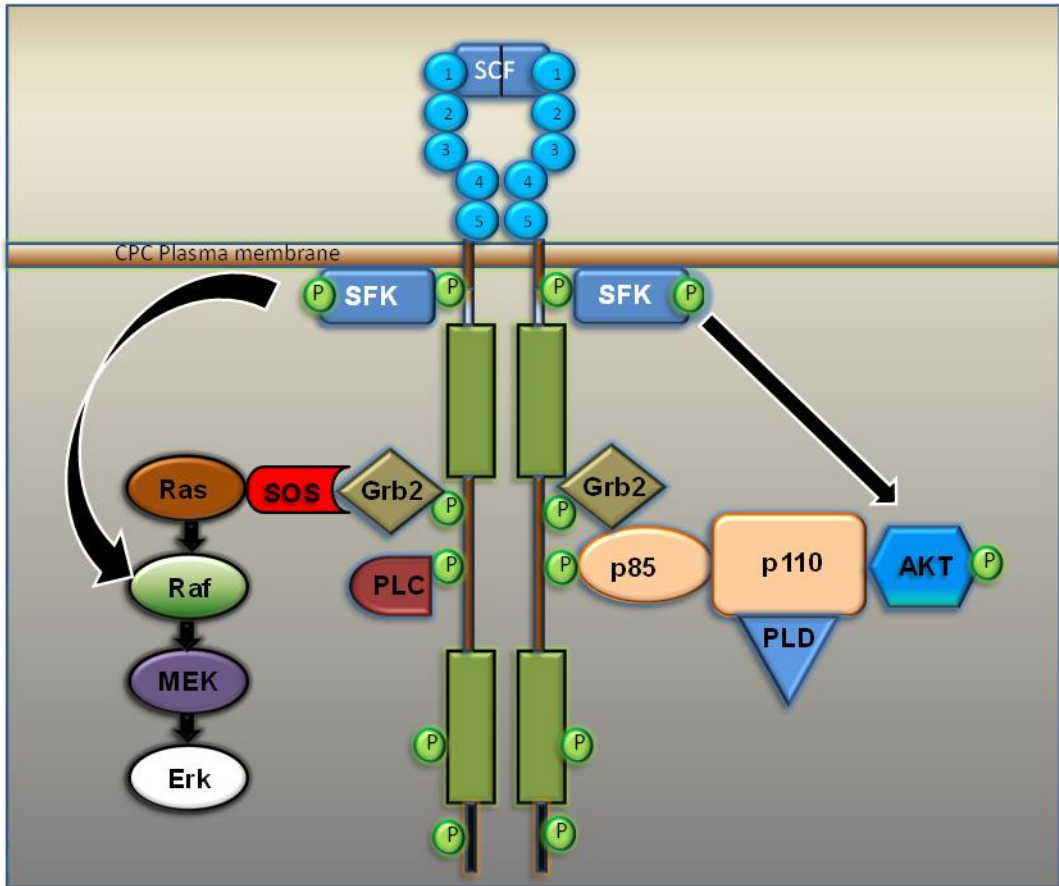

Figure 3: **Signal transduction in SCF activated c-kit receptor:** The ligand for c-kit, SCF binds to the c-kit receptor causing receptor dimerization and phosphorylation on key tyrosine residues. These residues act as a binding site for signal transduction molecules.

PI3-Kinase Pathway:

The phosphoinositide 3 kinase or PI3K pathway is considered to be a major pathway activated upon c-kit stimulation. Studies on SCF mediated c-kit activation in mast cells, endothelial cells and melanocytes [59, 99, 119, 120] have shown that this is an important pathway regulating genes that are involved in cell survival, proliferation, migration and differentiation. There are four major classes of PI3Ks and the Class I is further divided into class IA and IB. Since much of the published reports are on class 1A PI3Ks the discussion in this section will be limited to this subtype. Class IA PI3K has a regulatory subunit p85 and an enzymatic subunit p110 which can phosphorylate phosphoinositides [121]. p85 has SH2 domains through which it can bind to phosphorylated tyrosine residues. Upon autophosphorylation on its tyrosine residues, c-kit binds and activates PI3K either directly [122, 123] through its tyrosine 719 (in murine; Y721 in human) residue [124] or indirectly through the adapter protein GAB2 [125, 126]. This binding causes a conformational change thereby activating the enzymatic p110 subunit. PI3K is an intracellular lipid kinase which translocates to the membrane from the cytoplasm. Upon activation, it binds to and phosphorylates the 3' hydroxyl group of the membrane bound phosphoinositol 4, 5 biphosphate (PIP₂) to form phosphoinositol 3, 4, 5 trisphosphate (PIP₃). PIP₃ binds to proteins with plekstrin homology (PH) domains [127]. AKT, a serine/threonine kinase, binds to PIP₃ through its PH domain and the kinase PDK1 phosphorylates AKT making it active. AKT has to be phosphorylated on both a serine and threonine residue to become fully active [128, 129]. Activated AKT phosphorylates and regulates many downstream signaling proteins that influence growth and survival [130]. For example, AKT promotes cell survival by the phosphorylation and inactivation of the pro-apoptotic protein BAD [111]. Phosphorylation of BAD

disrupts its interaction with the anti-apoptotic proteins Bcl-X_L or Bcl-2 thereby antagonizing the pro-apoptotic BAX. Inhibition of BAX blocks cytochrome c release and hence apoptosis [131, 132]. AKT also promotes survival through the phosphorylation of forkhead transcription factor (FOXO) proteins by subjecting them to proteosomal degradation. Upon phosphorylation by AKT, FOXO proteins are retained in the cytoplasm and hence cannot promote the expression of pro-apoptotic genes [133]. AKT activation has been reported to be involved in the activation of mammalian target of rapamycin (mTOR) which in turn activates ribosomal S6 kinase leading to an increase in the transcription of pro-growth and anti-apoptotic genes [134, 135]. A schematic representation of this pathway is shown in Figure 4.

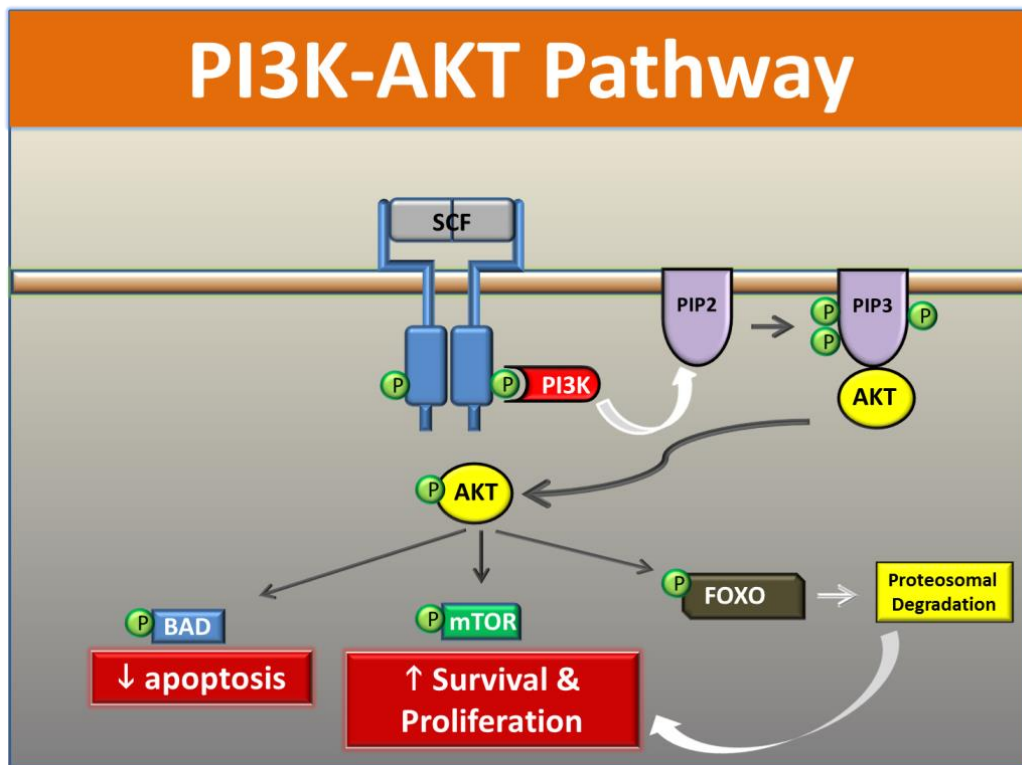

Figure 4: **Schematic representation of the PI3K-AKT signaling pathway.** Activation of the receptor by the ligand leads to the autophosphorylation of critical tyrosine residues and binding of the p85 subunit of PI3K through its SH2 domain and phosphorylation. Activation of PI3K phosphorylates and converts the membrane bound lipid PIP2 to PIP3 which binds and activates AKT. Activated AKT phosphorylates several downstream effectors including BAD, mTOR, FOXO regulating cellular proliferation, migration and apoptosis.

MAP Kinase Pathway:

The Mitogen Activated Protein Kinase (MAPK) pathway was found to be an essential pathway promoting proliferation and survival of mammalian cells [136, 137]. It is an important pathway that was found to be activated after c-kit stimulation in mast cells, melanocytes and hematopoietic cells [138-140]. Although c-kit activation can stimulate all four types of MAP kinases namely, ERK1/2, p38 MAPK, ERK5 and JNK, it is the ERK1/2 MAP kinase that has been studied extensively [141, 142]. Studies in melanocytes, endothelial cells and hematopoietic stem cells have shown that SCF stimulated c-kit leads to the activation of the ERK1/2 kinase regulating vital cellular properties [37, 143]. The cascade of signaling events starting from the receptor activation are as follows. Ligand activated c-kit binds to the adapter protein Grb-2 which binds to the guanine nucleotide exchange factor (GEF) SOS. SOS interacts with the membrane bound protein Ras and catalyzes the exchange of Ras bound GDP against GTP. Activated Ras binds to several effector proteins including B-Raf and activates them. B-Raf activates the dual specificity kinase MEK1/2 which in turn phosphorylates and activates ERK1/2 [99]. Phosphorylated ERK1/2 in turn regulates several proteins downstream including retinoblastoma protein [144], ribosomal protein S6 [145], glycogen synthase kinase 3 (GSK3) [146] and microphthalmia associated transcription factor (MITF) [147] thereby regulating cell proliferation, survival, migration and development. A schematic representation of the MEK-ERK pathway is given in Figure 5.

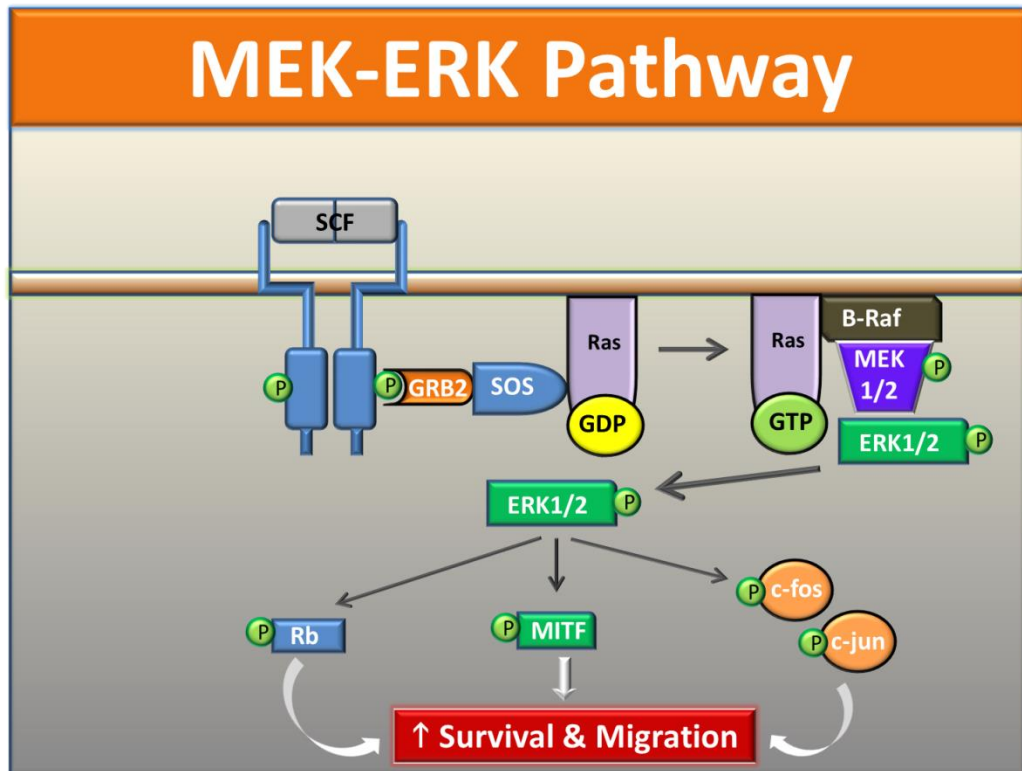

Figure 5: **Schematic representation of the MEK-ERK signaling pathway.** Activation of the receptor by the ligand leads to the autophosphorylation of critical tyrosine residues and binding of the adapter protein Grb2. The GEF protein SOS binds Grb2 and catalyzes the exchange of Ras bound GDP for GTP. Activated GTP bound Ras binds to and activates B-Raf which in turn phosphorylates and activates MEK1/2. MEK1/2 is a dual specificity kinase and phosphorylates ERK1/2 on its Thr and Tyr residues. Erk1/2 has a plethora of downstream effectors including Rb, MITF, c-fos and c-jun that are responsible for cell cycle regulation, survival and migration of cells.

Project Overview:

With all the above evidences, it is clear that CPCs are a group of resident progenitor cells in the heart that is essential for cardiovascular regeneration both in animal models and in humans. Also, the activation of c-kit receptor is important for the proliferation, survival and migration of many c-kit positive cell types under steady state and stress conditions. Hence, in this work I focused on exploring the role of c-kit in regulating the different cellular characteristics of CPCs isolated from endomyocardial biopsy samples from the patients. I hypothesized that c-kit has a role in the proliferation, apoptosis, migration and differentiation of CPCs. In Aim 1, I demonstrate that activation of the c-kit receptor with its ligand SCF promotes CPC proliferation, migration and reduces apoptosis under conditions of serum depletion. In Aim 2, with the use of specific pharmacological inhibitors, I demonstrate the involvement of the PI3K-AKT and MEK-ERK pathways in mediating the pro-survival, pro-growth and chemotactic effects of SCF-c-kit axis in CPCs. An overview of this work is depicted in Figure 6.

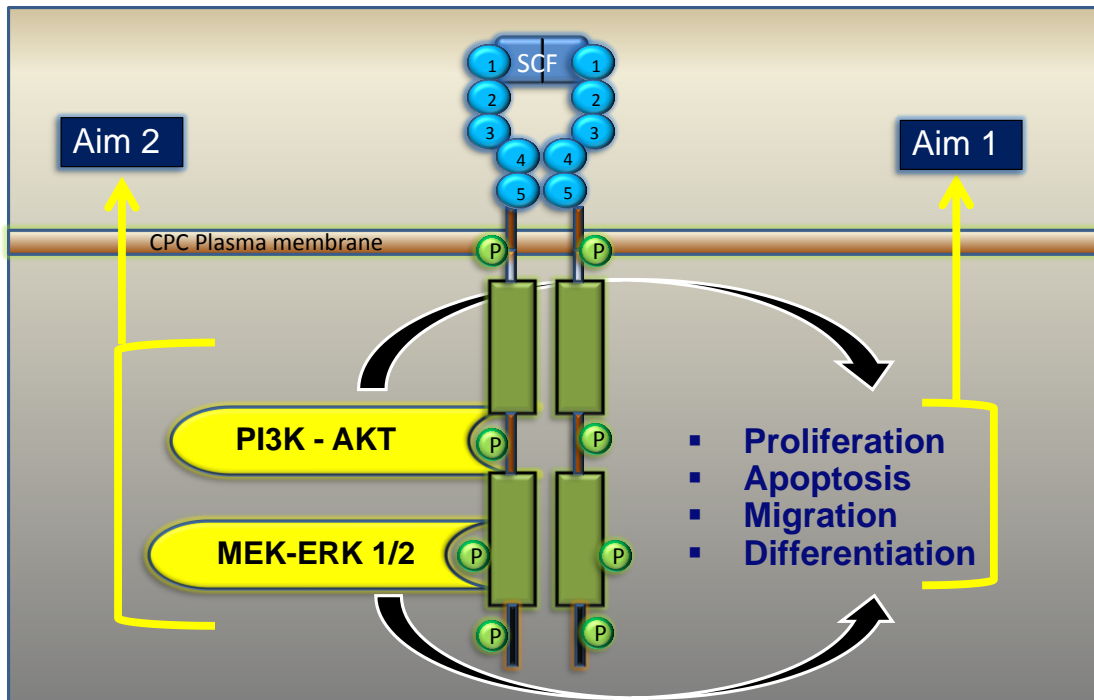

Figure 6: **Schematic representation of the project:** The goal of this project is to explore the role of c-kit in the proliferation, apoptosis, migration and differentiation of CPCs. Aim 1 tests the effect of SCF activated c-kit on the above cellular characteristics and aim 2 tests the involvement of PI3K-AKT and MEK-ERK pathways in mediating the SCF mediated cellular effects in CPCs.

CHAPTER II

ROLE OF C-KIT IN THE GROWTH, MIGRATION AND DIFFERENTIATION OF HUMAN CARDIAC PROGENITOR CELLS

Introduction:

Cardiovascular diseases are the leading cause of morbidity and mortality in the Western World [148]. Myocardial ischemia or infarction that occurs due to compromised blood supply to the heart results in extensive tissue damage and loss of functional cardiomyocytes. This results in cardiac hypertrophy and ventricular dilatation contributing to heart failure with a poor clinical prognosis [149, 150]. In this context, several attempts have been made to regenerate the injured myocardium with the help of different stem/progenitor cell populations that are present exogenous or endogenous to the heart. Exogenous sources including hematopoietic stem/progenitor cells [91], embryonic stem cells [151] and induced pluripotent stem cells [152] have been used to regenerate the injured myocardium, although to a variable extent. Endogenously, at least seven different types of cardiac progenitor cells have been identified and used to regenerate the dead tissue of the myocardium. They are the c-kit⁺ CPCs, Sca1⁺ CPCs, side population (SP) cells, cardiosphere derived cells (CDCs), cardiac resident colony forming unit fibroblasts, cardiac mesangioblasts and Isl1⁺ cells [4, 7-19] [153, 154]. Among these cells, only two of them were tested clinically on humans. CADUCEUS trial injected autologous CDCs to patients with left ventricular dysfunction after myocardial infarction (MI) and found that these cells are safe and capable of regenerating the infarcted myocardium [155]. In SCIPIO, intra coronary injection of patient derived c-kit⁺ CPCs

promoted cardiac regeneration in heart failure patients [6]. While the CDCs contain heterogeneous population of cells comprising of c-kit⁺ cells, CD90⁺ (Thy1) cells, endothelial cells (CD31⁺), endothelial progenitor cells (CD34⁺) that are negative for pan-hematopoietic marker CD45 [15, 156, 157], the SCIPIO trial injected only the c-kit⁺ CPCs and found significant clinical improvement in the injected patients. The discovery of endogenous CPCs that has the potential to regenerate the injured myocardium opened new avenues of cardiac regenerative therapy. The use of CPCs in cardiac regeneration also led to the initiation of several studies aimed at finding methods and key proteins that are essential to optimize the efficiency of cellular transplantation. Although these CPCs provide excellent clinical improvement after transplantation, there are many challenges identified in the process. These cells have poor survival and nearly 95% of the cells viable at 5 minutes after injection are lost within a week after transplantation [34]. Also poor engraftment and homing of these cells are a major concern [34, 158-160]. A number of studies identified several cytokines, enzymes and signaling molecules and demonstrated enhanced survival and better homing of CPCs by targeting them [161, 162]. This area also intrigued us to find ways to improve the therapeutic outcome of CPC transplantation. In light of the essential role of c-kit in other cell types as discussed in chapter 1 of this manuscript, I studied the role of c-kit activation in regulating the growth, survival, migration and differentiation of CPCs. Even though studies on c-kit have established the antigen as a pro-survival, anti-apoptotic, mitogenic and pro-migratory agent in a variety of cell types [35-37, 40, 53, 163-165], the role of c-kit in CPCs remains elusive. Hence to my knowledge this is the first attempt to characterize the role of this receptor protein in the regulation of cellular properties in CPCs.

Materials and Methods:

Isolation and culture of c-kit⁺/lin⁻ human cardiac progenitor cells

Isolation and characterization of c-kit⁺/lin⁻ human CPCs were done as described previously [7, 166]. Briefly, atrial appendages obtained from ischemic cardiomyopathy patients undergoing endomyocardial biopsy were enzymatically digested and cultured in complete growth medium (Ham's F12 media containing 10% fetal bovine serum, 10 ng/ml bFGF [PeproTech], 0.005 U/ml human erythropoietin [Sigma], and 0.2 mM L-glutathione [Sigma]). Media was changed every two days. MACS kit (Miltenyl Biotec) was used to enrich for c-kit⁺/lin⁻ CPCs following the manufacturer's instructions and as described previously [166]. Ham's F12 media with 0.2 mM L-glutathione was used as assay medium for all the experiments unless mentioned otherwise.

Cell growth and viability

Manual cell counting or PrestoBlueTM (Invitrogen) was used to assess cell growth and viability. For manual cell counting, approximately 50,000 cells were plated per well of a 24-well plate. CPCs were then serum starved for 24 hr and treated with or without 100 ng/ml SCF in serum free media. For bFGF and VEGF treatments, CPCs were incubated with 50 ng/ml bFGF (PeproTech) or 20 ng/ml VEGF (Invitrogen) either alone or in combination with SCF as indicated. After 3 days of growth factor treatment, cells were trypsinized and counted using a hemacytometer. For measurement of cell viability using PrestoBlueTM, 10,000 CPCs were plated per well of a 96-well plate. When indicated, CPCs were treated with 0.5 μ M imatinib mesylate (Cayman Chemicals) for 2 hr prior to SCF treatment. PrestoBlueTM cell viability assay was performed 72 hr post-growth factor treatment according to the

manufacturer's instructions. Briefly, the 10x reagent was mixed with an appropriate volume of serum free medium, added to the cells and incubated at 37 °C for an hr. The viability was assessed by measuring the fluorescence at Ex/Em 560/590 nm.

BrdU assay

Approximately 10,000 cells per well were plated on a 96-well tissue culture plate. Cells were serum-starved for 24 hr followed by treatment with 20 μ M BrdU for 24 or 72 hr in the presence or absence of SCF in the assay medium. After BrdU labeling, cells were fixed and immunostained using anti-BrdU antibody (at 1 in 1,000; Sigma-Aldrich #B8434) and Alexa555-conjugated secondary antibody (at 1 in 1,000; Invitrogen). Images were captured using EVOS® FL Cell Imaging System (Life Technologies), and the BrdU-positive cells were counted manually.

Caspase assay

Apo-ONE® Homogeneous Caspase-3/7 Assay kit (Promega) was used to measure the caspase activity in CPCs according to the manufacturer's instructions. Briefly, approximately 10,000 CPCs were plated per well. The next day, the medium was changed to serum free media or same media containing SCF. After 3 days of SCF treatment, the caspase activity in the cells was measured by adding the pro-fluorescent substrate and reading the fluorescence at Ex/Em 499/521 nm. The values were normalized to the untreated control.

Oxidative stress by DMNQ and H₂O₂

For DMNQ experiments, approximately 10,000 human c-kit⁺ CPCs per well were plated on a 96-well tissue culture plate. On the next day, cells were treated with

100 ng/ml SCF in serum free media. For the imatinib treatment groups, cells were treated with 0.5 μ M imatinib for 2 hr prior to the SCF treatment. On the second day, CPCs were subjected to 8 μ M DMNQ (dimethoxy-naphthoquinone; Sigma) treatment in the groups indicated. After 3 days of DMNQ treatment, cell viability was assessed using PrestoBlue™. For H₂O₂ experiments, approximately 10,000 cells per well were plated on a 96-well tissue culture plate. On the next day, cells were treated with 100 ng/ml SCF or 10 μ g/ml insulin (Gibco) in serum free media. On the following day, CPCs were subjected to 0.5 mM H₂O₂ (EMD Chemicals) treatment for 1 hr. Cell viability was assessed 3 days later using PrestoBlue™.

Western blot analysis

Cells were harvested with Laemlli buffer and heated for 10 minutes at 100 °C. Protein concentration was estimated using bicinchoninic acid (BCA) assay kit purchased from Thermo scientific following manufacturer's instructions. Before loading the samples on the gel, 3 μ l of β -mercaptoethanol was added per 100 μ l of sample and heated for 3 minutes at 100 °C. Cell lysate (25 or 50 μ g of protein) was loaded on 4-20% Tris-Glycine gel and separated by electrophoresis. The separated proteins were transferred to a PVDF membrane, blocked with 5% skim milk or 5% bovine serum albumin for 1 hr followed by probing with primary antibody overnight at 4 °C. The blot was then incubated with HRP-conjugated secondary antibody for 1 hr and developed using Amersham ECL Prime Western Blotting Detection Reagent (GE Healthcare). Primary antibodies used were anti-c-kit (1 in 500; abcam #32363), anti-phospho c-kit (Y703; 1 in 500; Cell Signaling #3073P) and anti- α -tubulin (1 in 3,000; Sigma #T6074).

***In vitro* cell migration**

Boyden chambers containing transwells (24-well plate format) with 8 μm pore size were purchased from Corning. Typically, 30,000 – 40,000 cells were plated in the upper chamber of the transwell. After 24 hr, the medium in the upper chamber was changed to assay medium and bottom chamber was filled with the same medium alone or medium containing 100 ng/ml SCF. For inhibition of c-kit activity, cells were pre-treated with 0.5 μM imatinib for 2 hr prior to the SCF treatment. After 24 hr, the cells migrated to the lower surface of the transwell membrane were fixed with 3.7% formaldehyde for 10 minutes, and the cells still remaining on the upper chamber were scraped off. The fixed cells were then permeabilized with 0.25% Triton X-100 in PBS for 10 minutes followed by incubation with 50 $\mu\text{g/ml}$ propidium iodide solution for 10-15 minutes. Images were acquired using EVOS® FL Cell Imaging System (Life Technologies), and the number of migrated cells was quantified using the NIS-Elements (version 4.2) software.

Clonogenicity assay:

Individual cells were plated on a 96 well plate by limiting dilution method. Briefly, CPCs were diluted with appropriate volume of growth media to achieve 1 cell per 100 μl of medium and plated on a 96 well plate. Individual cells were screened and treated with 100 ng/ml SCF or left untreated. Medium was replacement every 5 days and individual CPCs were followed up for 14 days for the formation of clones. The percentage clonogenicity was calculated from the number of individual cells tracked to the cells among them that formed clones.

Dexamethasone induced differentiation of CPCs:

Approximately 100,000 CPCs were plated on a 12 well plate in growth media. 24 hours after plating the cells, time 0 control (undifferentiated) was harvested with TRIzol following the manufacturer's instructions. For the remaining cells, the media was changed to DMEM with 5% fetal bovine serum containing 10 nM dexamethasone or 100 ng/ml SCF or a combination of both or DMSO (control). Medium was replaced every alternate day up to 2 weeks (hCPCs) or 4 weeks (mCPCs) at the end of which the cells were harvested with TRIzol and stored at -80 °C until required. RNA was isolated from the samples stored at -80°C using Qiagen's RNEasy Mini Kit (Cat. 74106) following manufacturer's protocol and the concentration was measured using a nanodrop. 250 ng of RNA was used to perform cDNA synthesis using AffinityScript Multiple Temperature Reverse Transcriptase kit (Cat. 600105) following manufacturer's instructions. Real-time PCR for different markers listed was performed with the harvested samples in a 10 µl reaction using the primers listed below, SYBR Green PCR master mix and Stepone Plus real-time PCR machine (Applied Biosystems). The results were analyzed using the Stepone software.

Lentivirus production and transduction

The lentivirus carrying mCherry or FLAG-tagged murine c-kit was produced by using the ViraPower™ Lentiviral Expression System and pLenti6-V5 vector (Invitrogen) according to the manufacturer's instructions. Virus was concentrated using the Lenti-X Concentrator (Clontech) and was stored at -80 °C until its use. On the day of the experiment, CPCs were transduced with complete medium containing either mCherry or c-kit virus and 6 µg/ml polybrene (Sigma). On the following day,

the media was replaced with fresh complete media. Cells were cultured for 5 days to allow expression of mCherry or c-kit prior to being used for the experiments.

Statistical analysis

Statistical analysis was performed by Mann-Whitney U test using SPSS ver. 17 software. Data are presented as mean \pm SEM. SEM is an estimate of the precision of mean and often used in scientific studies. P value of <0.05 was considered as statistically significant.

Results:

c-Kit⁺ CPCs express functional c-kit receptors:

First, I tested to confirm if human CPCs express functional c-kit receptors. Western blot analysis confirmed expression of c-kit in CPCs, and treatment of CPCs with the c-kit ligand SCF increased the level of tyrosine phosphorylation of the c-kit receptor (Figure 7). In addition, pre-treatment of the cells with the c-kit inhibitor, imatinib abolished the SCF-induced phosphorylation of the receptor as expected (Figure 7). This indicates that human CPCs express functional c-kit receptors that can be activated by its ligand SCF.

c-Kit activation promotes growth and survival of human c-kit⁺ CPCs

I then tested if SCF/c-kit signaling can act as a pro-growth or pro-survival pathway when CPCs are subjected to conditions of stress. I first examined if serum starvation could be an ideal condition to study the pro-survival or pro-growth effect of SCF by growing CPCs under different degrees of serum starvation in the presence or absence of the kit ligand SCF. I found that when CPCs are grown in conditions containing less than 10% serum, activation of c-kit increased the number of viable

CPCs compared to the untreated control (data not shown). I used serum free media for subsequent experiments to avoid the effect of known and unknown growth factors present in the serum which may influence CPC survival or growth. In the next step, I tested if c-kit activation could rescue the CPCs grown under serum starvation by treating them with or without SCF and measuring the cell number on each day until 5 days post-SCF treatment (Figure 8A). Compared to the vehicle control, SCF treatment resulted in a significantly greater number of cells starting at day 3 and up to day 5. Moreover, the pro-survival or pro-growth effect of SCF on CPCs was dose-dependent, and its effect plateaued at 100 ng/ml (Figures 8B and C). Hence, 100 ng/ml concentration of SCF was chosen for all the subsequent experiments. Next, I compared the effect of SCF with those of other growth factors, including vascular endothelial growth factor (VEGF) and basic FGF (bFGF), either alone or in combination with SCF, in CPCs grown under serum starvation. Although the pro-survival or growth effect of SCF was comparable to that of bFGF in CPCs (Figure 8D), I did not find any additional or synergistic effect when cells were treated with a combination of growth factors (Figure 6D), suggesting that they share similar downstream signaling pathways. To further confirm these findings, I overexpressed c-kit (or mCherry as a control) in human CPCs using lentivirus and subjected the cells to serum starvation in the presence or absence of SCF (Figure 9A). As expected, overexpression of c-kit resulted in a further increase in the number of viable cells when treated with SCF (Figure 9B). Such effect was abolished by pre-treatment of cells with imatinib, the c-kit inhibitor, suggesting that the effect of SCF on CPCs is indeed mediated through c-kit receptor (Figure 9B). These results together indicate that SCF-mediated activation of c-kit enhance survival or growth of CPCs cultured under serum starvation.

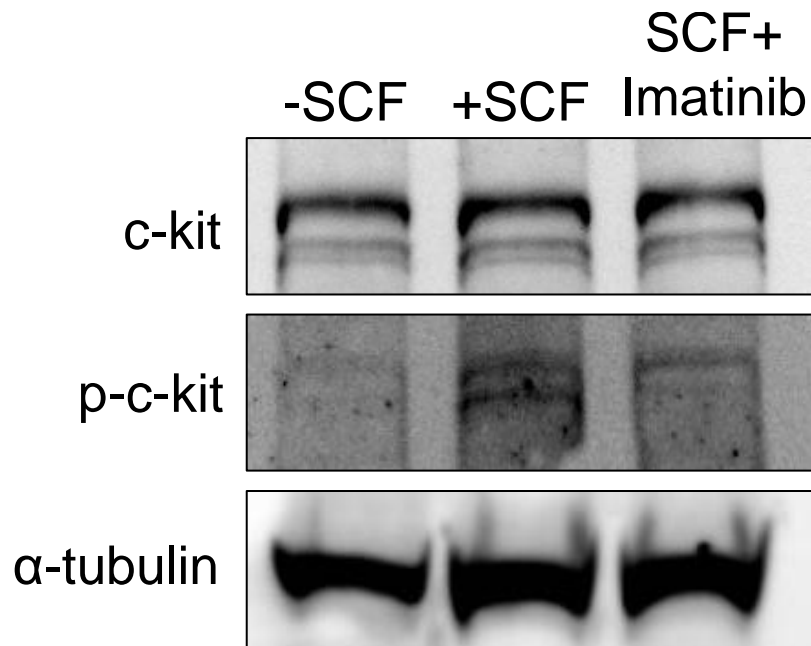
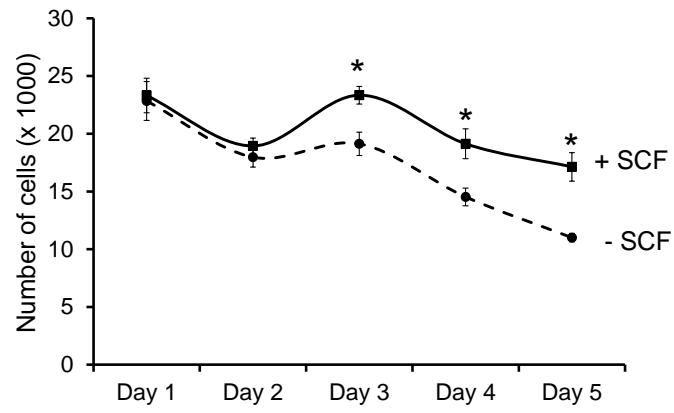
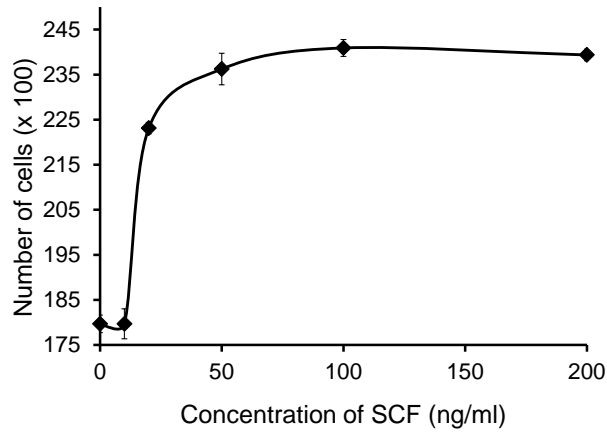

Figure 7: **Activation of c-kit by SCF in human c-kit+ CPCs.** CPCs were either treated with SCF (100 ng/ml) alone for 10 minutes or co-treated with imatinib. Cell lysate was analyzed by Western blot for the indicated proteins. p-c-kit, phosphorylated (i.e., activated) c-kit (n=2).

A



B



C

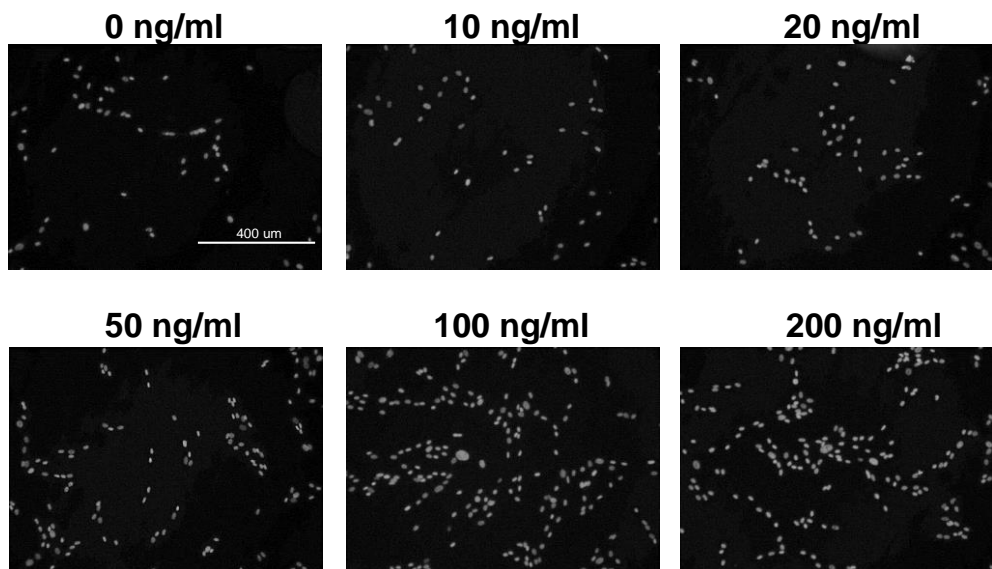

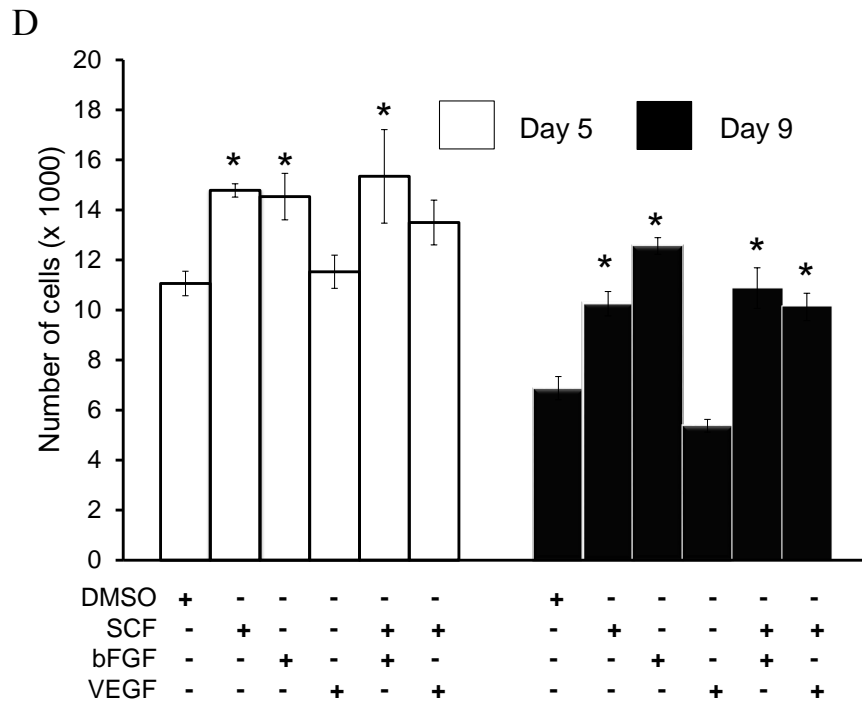

Figure 8: **c-Kit activation promotes growth of human c-kit⁺ CPCs under serum starvation.** A, The effect of SCF on cell growth. CPCs were serum starved for 24 hr and treated with SCF. The number of cells remaining was counted at the indicated time points (n=1). B, Dose-response relationship between SCF and CPC growth. CPCs were serum starved for 24 hr followed by treatment with varying concentrations of SCF, and the number of cells remaining after 3 days was determined (n=3). C, Representative DAPI nuclear staining images of SCF-treated CPCs described in panel C. D, Comparison of SCF with bFGF and VEGF in promoting growth of CPCs. CPCs were serum starved for 24 hr and treated with SCF, bFGF, or VEGF either individually or in combination, and the number of cells were counted on days 5 and 9 of treatment (n=2). Values are presented as mean \pm SEM. *, p<0.05.

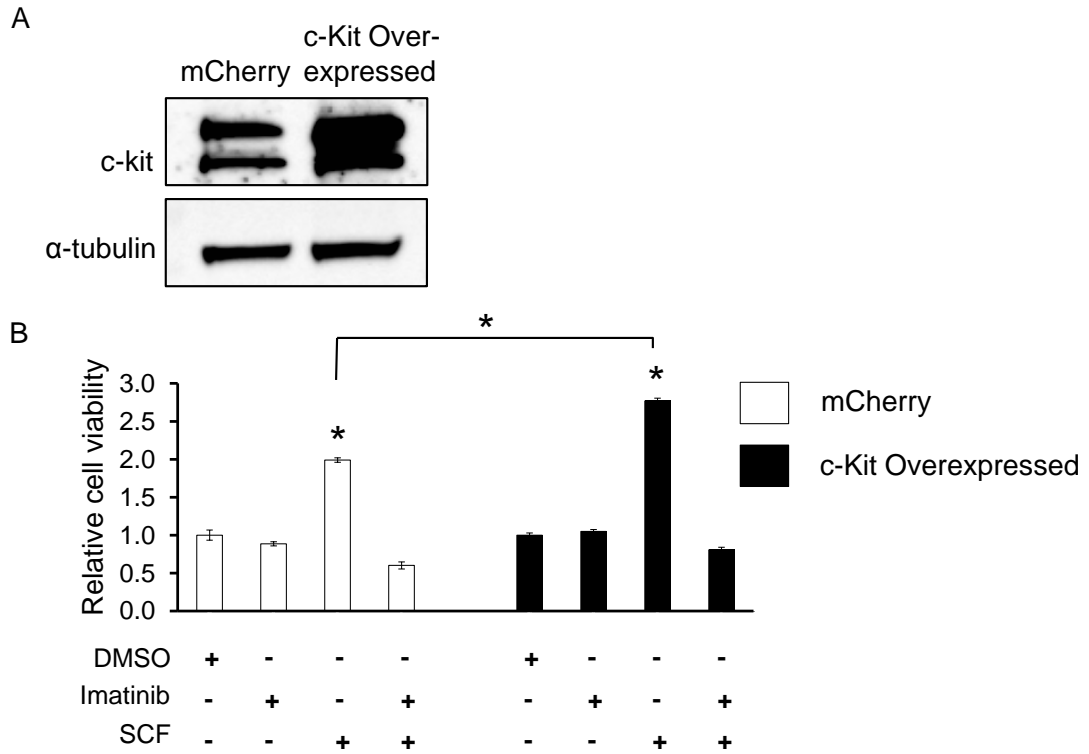

Figure 9: c-Kit over expression further increases CPC survival under serum starvation. A, Human c-kit⁺ CPCs were transduced with lentivirus expressing mCherry (control) or c-kit. Cell lysates were obtained at 4 days post-viral transduction and immunoblotted for c-kit and α -tubulin (loading control). B, mCherry or c-kit-expressing CPCs were serum starved for 24 hr and cultured for 3 days in the presence (+) or absence (-) of SCF and/or imatinib as indicated. Cell viability was assessed using PrestoBlueTM as described. Values were normalized to the DMSO (vehicle) control (n=3). Values are presented as mean \pm SEM. *, p<0.05.

c-Kit activation fails to rescue CPCs from oxidative stress

I then tested if SCF can also prevent cell death induced by other stress conditions, such as oxidative stress, in CPCs. For this, CPCs were pre-treated with SCF for 24 hours followed by treatment with an oxidative stress inducer, dimethoxy-naphthoquinone (DMNQ) or H₂O₂. Of note, DMNQ is a quinone that induces superoxide anion formation by redox cycling [167], whereas H₂O₂ undergoes Fenton reaction in the presence of iron and produces reactive oxygen species, causing cell injury and death [168]. As shown in Figure 10A, DMNQ treatment led to a significant decrease in the number of cells. However, pre-treating the cells with SCF failed to prevent the cell death induced by DMNQ treatment (Figure 8A). Correspondingly, SCF treatment of CPCs was not able to prevent or attenuate the cell death following H₂O₂-induced oxidative stress (Figure 10B). Similar results were obtained upon pre-treating CPCs with varying concentrations of SCF ranging from 10 ng/ml to 200 ng/ml (data not shown). In contrast, insulin pre-treatment (a positive control) was able to rescue CPCs from H₂O₂-induced oxidative stress (Figure 10B). Taken together, these results demonstrate that while SCF-induced activation of c-kit promotes survival of CPCs grown under serum depletion, it does not rescue CPCs subjected to oxidative stress.

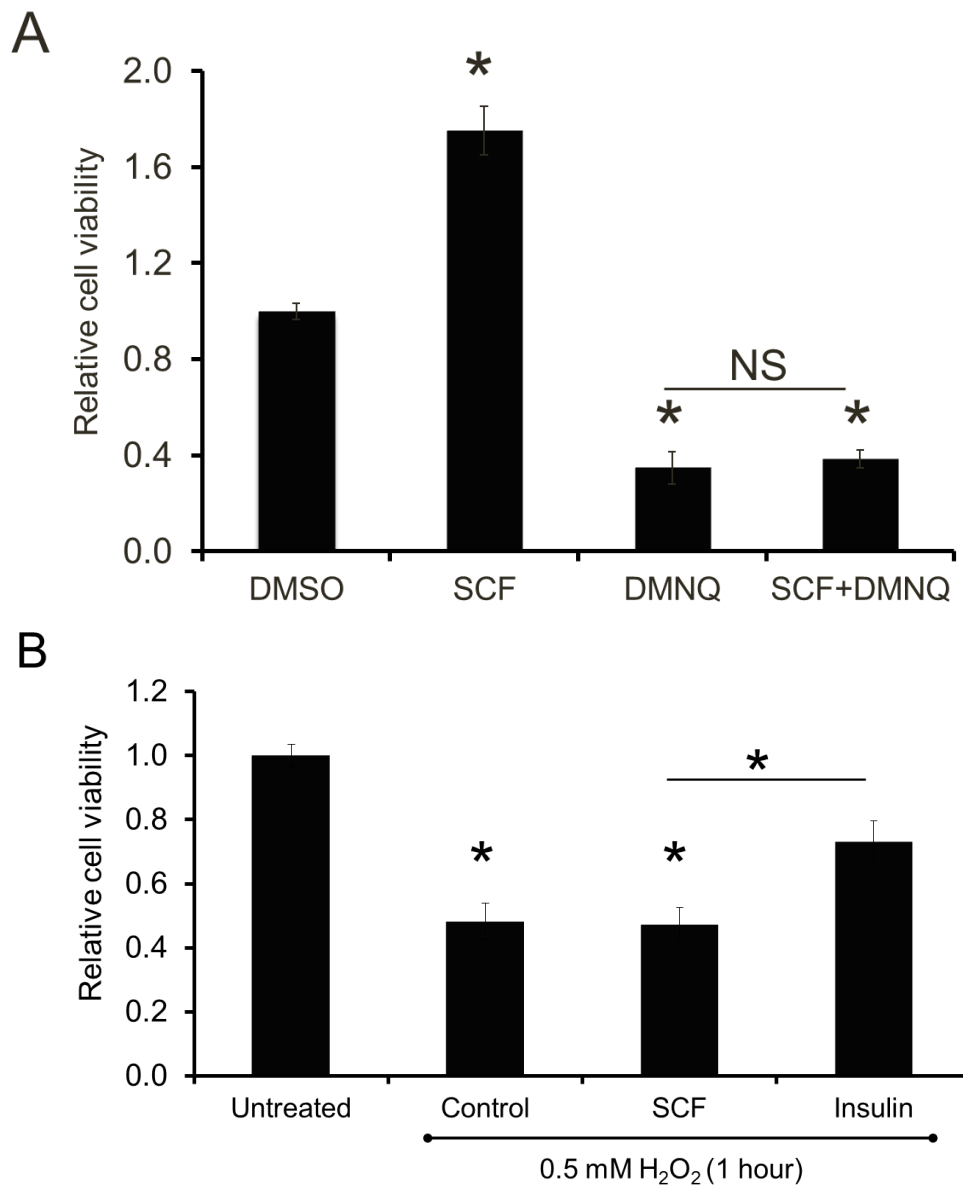

Figure 10: **c-Kit activation does not rescue CPCs from oxidative stress.** A, Human c-kit⁺ CPCs were pre-treated with SCF for 24 hr in serum free media and subjected to 8 μ M DMNQ treatment (n=2). B, Cells pre-treated with or without SCF received 1 hr treatment in 0.5 mM H₂O₂, followed by media change with or without SCF. Insulin was used as a positive control. Cell viability was assessed after 3 days using PrestoBlueTM. *, p<0.05 compared to the untreated control, #, p<0.05 compared to the H₂O₂ only control. NS, no statistical significance (n=2). Values presented are mean \pm SEM.

c-Kit activation leads to increased proliferation of CPCs

In order to test whether the observed increase in the number of viable cells was due to the mitogenic effect of SCF/c-kit signaling, I performed a BrdU labeling assay [169]. For this assay, I cultured the cells under serum starvation in the presence or absence of SCF and incubated them with BrdU for 24 hr starting at different time points. When compared to the control, SCF increased the BrdU labeling index in CPCs during days 2 and 3 of the treatment, suggesting that SCF treatment promotes proliferation in CPCs (Figure 11A). However, the difference between the two treatment groups did not reach statistical significance. Next, I treated the cells with BrdU continuously for 3 days with or without SCF. With continuous BrdU supply and SCF treatment, the percentage of BrdU-positive CPCs increased to $10.2 \pm 3.9\%$ (SCF-treated group) from $3.9 \pm 3.4\%$ (untreated control group), significantly raising the rate of proliferation by more than 2-fold (Figure 11B). This demonstrates that SCF acts as a mitogen for CPCs under conditions that restrict their growth.

c-Kit activation reduces apoptosis of CPCs under serum starvation.

I then examined if SCF besides acting as a mitogen, can reduce apoptosis of CPCs grown under serum depletion conditions. For this purpose, I measured the activity of caspases 3 and 7 in CPCs after growing them under complete serum depletion for 3 days in the presence or absence of SCF. As shown in Figure 11C c-kit activation with SCF resulted in a significant reduction of caspase activity compared to the untreated control. Moreover, inhibiting c-kit with imatinib partially abolished this reduction in caspase activity (Figure 11C). These studies suggest that SCF dependent c-kit activation in addition to acting as a mitogen, also has an anti-apoptotic role in CPCs.

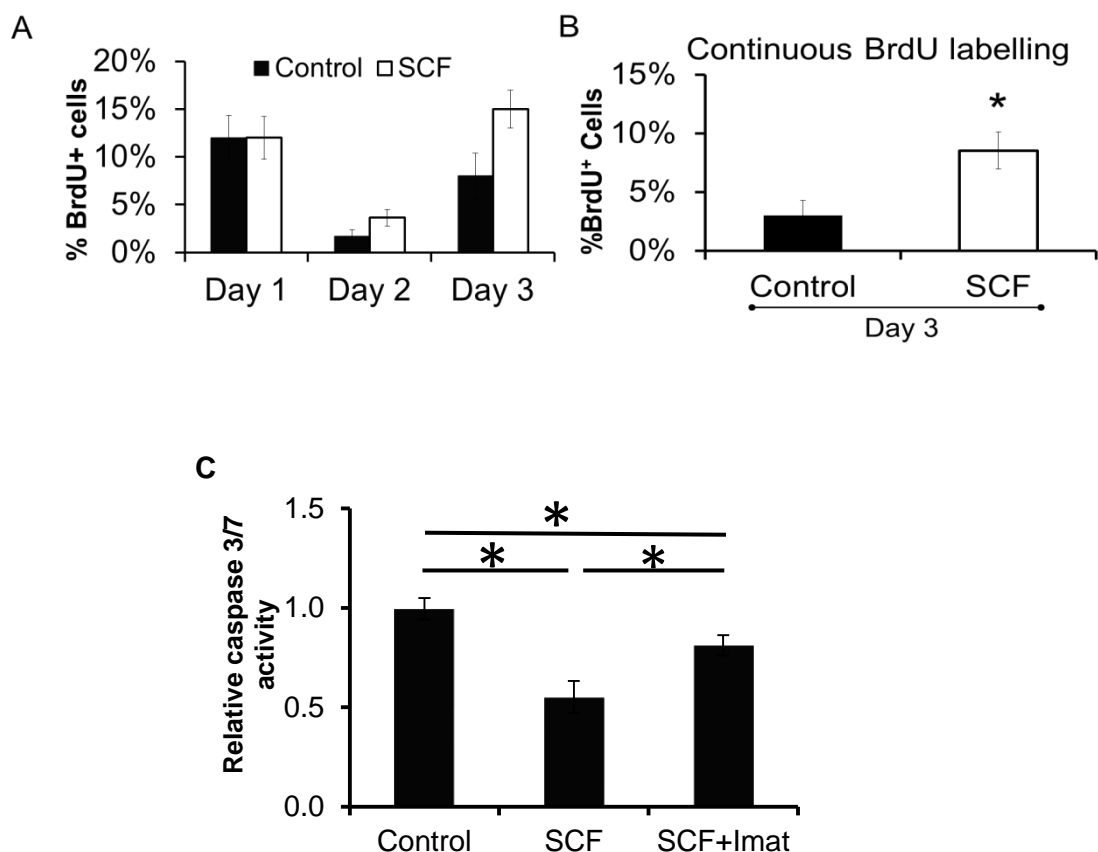
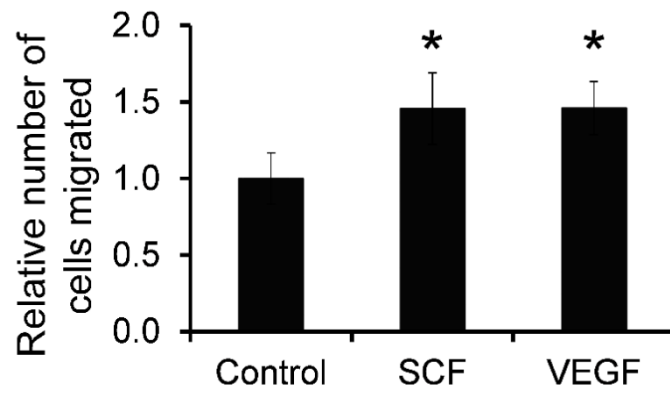

Figure 11: **c-Kit activation induces proliferation and decreases apoptotic cell death in CPCs.** Human c-kit⁺ CPCs were serum starved for 24 hr and labeled with BrdU in the presence or absence of SCF for 24 hr only for the indicated day (A, n=1) or continuously for 3 days (B, n=2). Cells were stained with anti-BrdU antibody, and the positive cells were expressed as the percentage of total nuclei. C, CPCs were grown in serum free media for 3 days. Activities of caspases 3 and 7 were measured and normalized to the untreated control (n=3). Imat – Imatinib. Values presented are mean \pm SEM. *, p<0.05.

c-Kit activation promotes migration of CPCs

For successful engraftment of the donor cells following transplantation, homing of the CPCs to the recipient myocardium and the injured area is required. Studies have shown that c-kit expression is important for the migration of several c-kit⁺ cell types including melanocytes [52], human umbilical vein endothelial cells (HUVEC) [59] and germ cells [170]. Hence I tested if the SCF-c-kit axis contributes to the migration of CPCs. To test this, I implemented the Boyden chamber and used SCF as a chemo attractant. I found that SCF significantly promoted the migration of CPCs and was comparable to VEGF (Figures 12A and B), which has previously been shown to promote migration of CPCs [161]. To further confirm the result, I overexpressed c-kit in CPCs with mCherry as a control using lentivirus and performed the same migration assay. As expected, upon c-kit overexpression and SCF treatment, the number of migrated cells was further increased compared to the mCherry-expressing control CPCs. Furthermore, inhibiting c-kit with imatinib abolished the pro-migratory effect of SCF/c-kit signaling observed (Figure 12C) suggesting that the chemotactic effect of SCF on CPCs are indeed mediated through the activation of c-kit receptor.

A



B

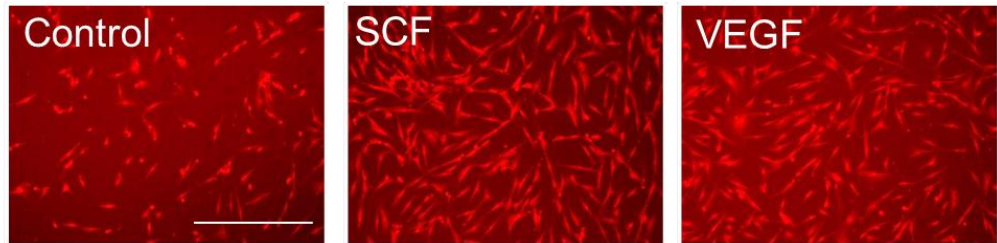

C

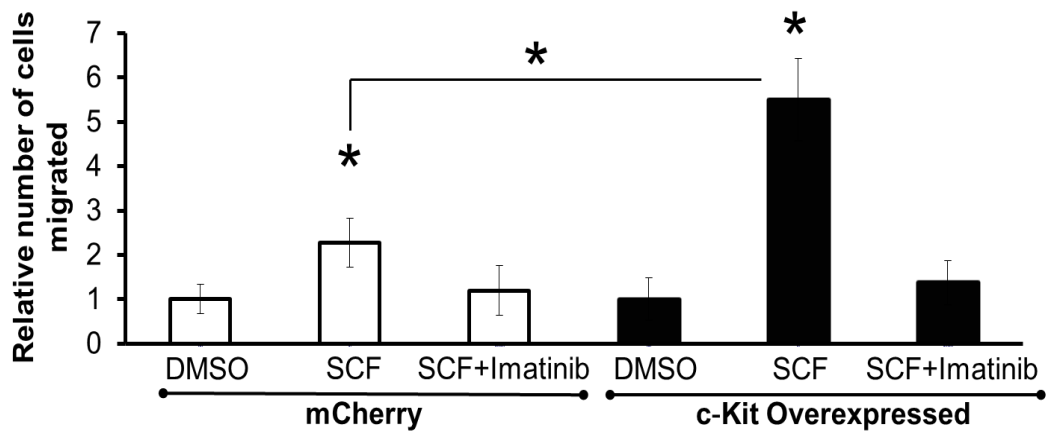

Figure 12: **c-Kit activation promotes migration of CPCs.** Boyden chamber assay. Human c-kit⁺ CPCs were plated in the upper chamber, and the indicated growth factors were used as a chemoattractant in the lower chamber. After 24 hr, the migrated cells were fixed, stained with propidium iodide, and counted. A, Comparison of the pro-migratory effect between SCF and VEGF (n=1). B, Representative images showing the cells migrated towards the indicated growth factors. C, CPCs transduced with lentivirus expressing mCherry (control) or c-kit were compared for their chemotaxis towards SCF in the presence (+) or absence (-) of 0.5 μ M imatinib (n=3). Values presented are mean \pm SEM. *, p<0.05.

c-Kit activation does not play an overt role in the differentiation of CPCs

One of the critical properties of stem/progenitor cells is their inherent ability to differentiate into cell types of multiple lineages [171]. It has been shown that c-kit⁺ CPCs are multipotent and can differentiate into cardiomyocytes, smooth muscle cells, fibroblasts and endothelial cells *in vitro* and *in vivo* [4, 5, 20]. I tested if the activation of c-kit contributes to the differentiation of CPCs (Figure 13). To test this, human CPCs were induced to differentiate with 10 nM dexamethasone (dex) treatment for 2 weeks and analyzed the expression of various endothelial (KDR), cardiogenic (Troponin-T, connexin-43, GATA4), mesenchymal/fibroblast (FSP1, DDR2, Vimentin) and smooth muscle cell markers (α SMA) (Figure 13A). We observed an increase in the mRNA expression levels of KDR and troponin-T in one sample (Patient 1) and DDR2 and FSP-1 in the other (Patient 2) when compared to the untreated control group. Also there was a decrease in the mRNA expression of other markers after two weeks of dex treatment. However, activation of the c-kit receptor with SCF did not significantly change the mRNA expression levels for most of the markers when compared to the untreated control group. As shown in Figure 13A, the results were variable between biological replicates and in most cases did not reach statistical significance when compared to the untreated control. In order to account for the variability between biological replicates, our group also tested the activation of c-kit in the differentiation of mouse CPCs (Figure 13B). Interestingly, we found an increase in a number of cardiogenic markers including ANP, BNP, α MHC, β MHC, troponin-I and troponin-T, but other lineage markers did not change significantly compared to the untreated control. Also, adding SCF alone or in combination with dex did not additionally contribute to the differentiation of CPCs. Considering that dex treatment was not able to induce robust differentiation with both

human and mouse CPCs, my aim to test the contribution of c-kit activation to the differentiation of CPCs remains inconclusive.

Activation of c-kit does not affect the clonogenicity and pluripotency of CPCs

c-Kit is widely known as a stem/progenitor cell marker but the contribution of c-kit activation to the clonogenicity and pluripotency of the stem/progenitor cells is not clear. To test this idea, first, I checked if c-kit activation can influence the clonogenicity of CPCs (Figure 14A). While we found that SCF dependent c-kit activation could promote the clonogenicity of CPCs cultured in the growth media containing 5% serum, the results were not reproducible. Similarly, my attempt to analyze the expression of pluripotent factors (Oct4, Nanog, Klf4, SOX2) upon c-kit activation did not yield significant results (Figure 14B). The expression of the pluripotent factors except for Klf4 at the mRNA level was undetermined. Additionally, c-kit activation or dex treatment did not change the klf4 expression significantly compared to the untreated control. In summary, my findings suggest that activation of c-kit does not affect the clonogenicity and pluripotency of CPCs.

A

Patient - 1

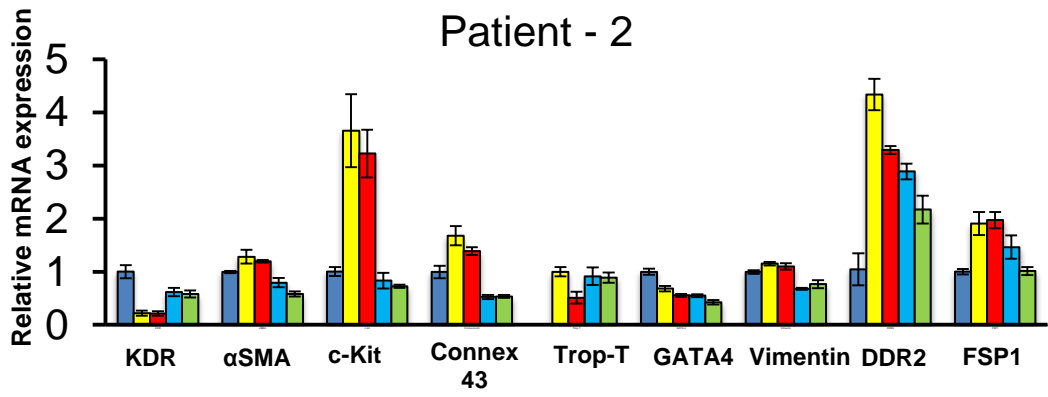
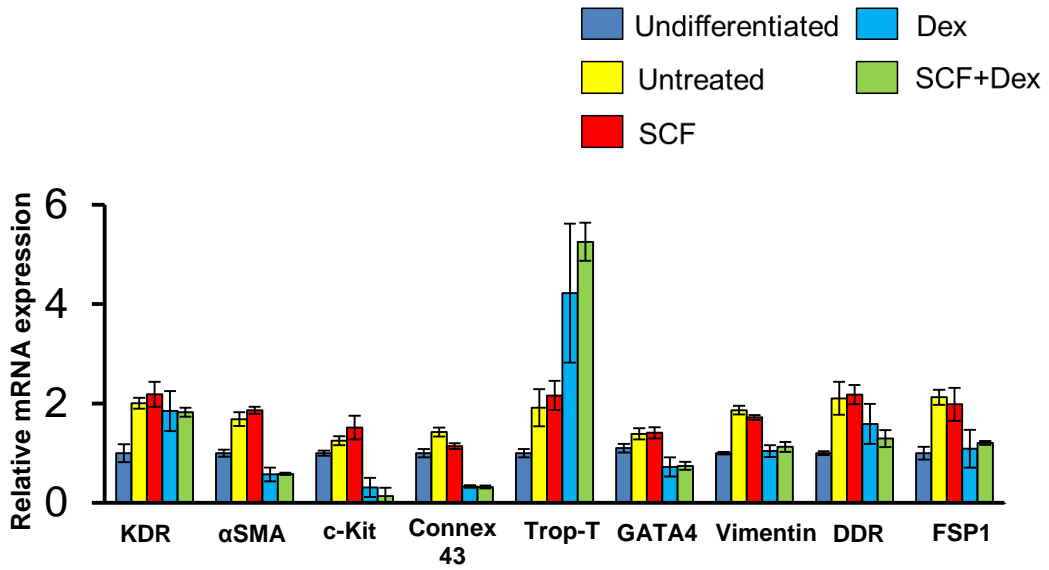

B

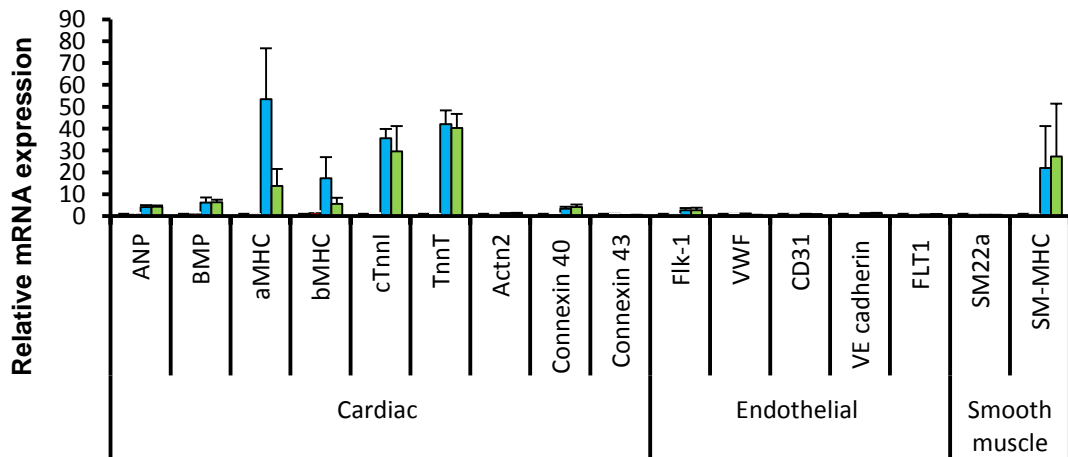

Figure 13: c-Kit activation does not play a role in the differentiation of CPCs.

Dexamethasone induced differentiation. A. Human c-kit⁺ CPCs were treated with 10 nM dexamethasone (Dex) or vehicle (Untreated) or SCF or Dex+SCF continuously for 2 weeks and analyzed for the expression of different markers as indicated. B. Mouse c-kit⁺ CPCs were treated with 10 nM dexamethasone (Dex) or vehicle (Untreated) or SCF or Dex+SCF continuously for 4 weeks and analyzed for the expression of different markers as indicated.

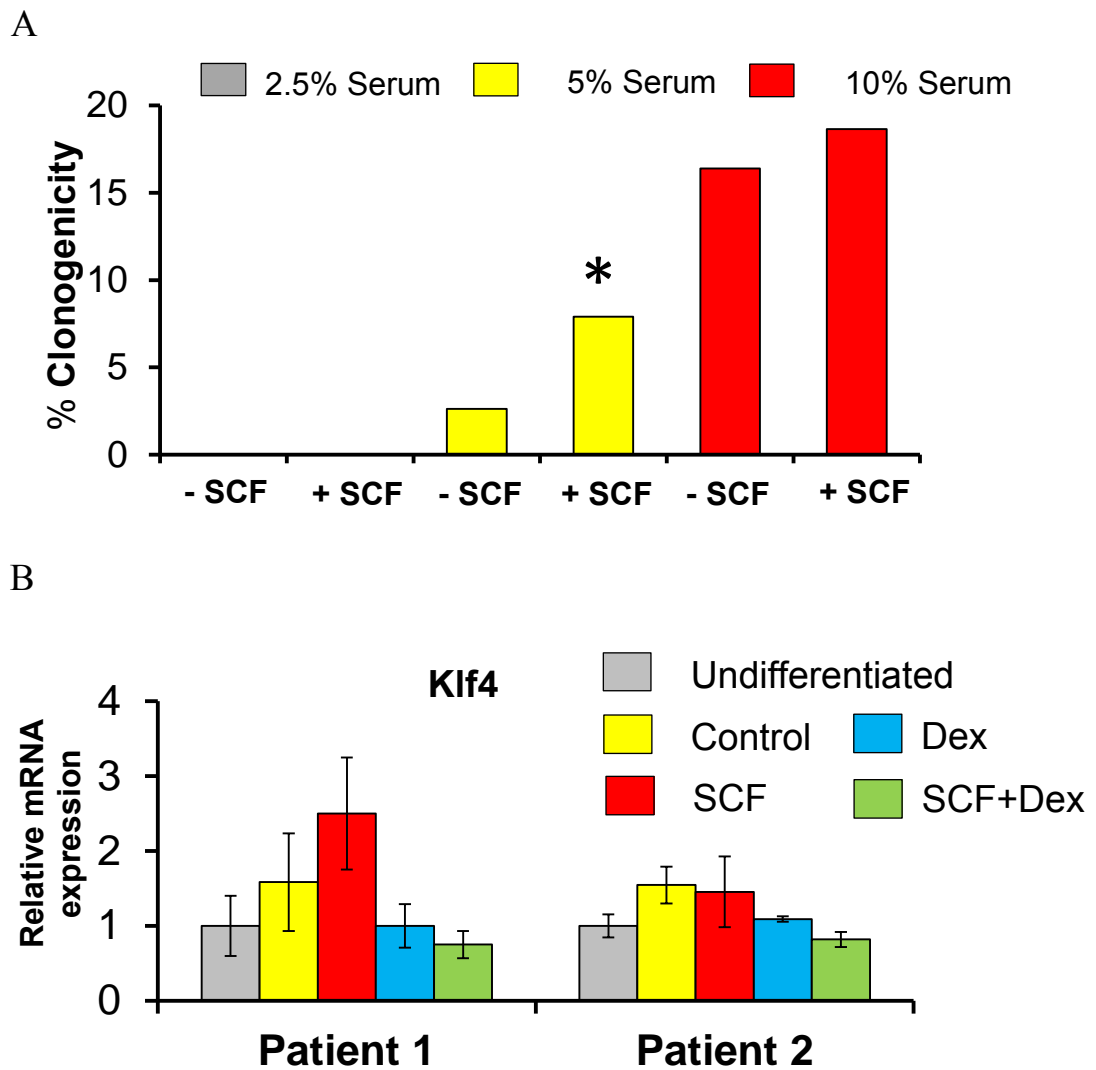

Figure 14: **c-Kit activation does not affect the clonogenicity and pluripotency of CPCs.** A. Individual human *c-kit*⁺ CPCs in growth media with different serum concentrations were treated with vehicle (control) or SCF for 2 weeks and analyzed for clonogenic cells (n=2). B. Patient derived *c-kit*⁺ CPCs were treated with 10 nM dexamethasone (Dex) or vehicle (Control) or SCF or Dex+SCF continuously for 2 weeks and analyzed for the mRNA expression of *klf4*, *nanog*, *oct4* and *sox2*. Only *klf4* was detectable (n=2). Values presented are mean \pm SEM. *, $p < 0.05$.

Discussion:

In the study presented here, I have shown that activation of c-kit promotes the growth, survival and migration of CPCs cultured under serum deprived conditions. In addition, the data shows that the pro-growth/survival and pro-migratory effect is even more pronounced when c-kit is overexpressed and the same is abolished when c-kit activation is suppressed with imatinib. The results of this study imply that the SCF/c-kit signaling pathway in CPCs can be exploited to overcome one of the major problems in the current field of cardiac cell therapy: poor survival and engraftment of the transplanted cells.

Although this is the first study to establish the role of c-kit in the regulation of growth, survival and migration of CPCs, the present findings are consistent with previous studies that have emphasized the importance of c-kit activation in cardiac remodeling after MI. For example, a study by Xiang *et al* indicated that cardiomyocyte specific overexpression of SCF can enhance cardiac repair, heart function and the overall survival of the animal after myocardial infarction [172]. The overexpression of SCF in the cardiomyocytes significantly reduced cellular apoptosis in the peri-infarct area. The SCF overexpression was accompanied by a decreased end diastolic volume and better cardiac function compared to the control groups. Activation of the SCF-c-kit axis also attenuated MI-induced hypertrophy and significantly increased the capillary density in the peri-infarct area compared to the controls indicating that the pathway promotes angiogenesis and cardiac repair. Interestingly, SCF overexpression also increased the recruitment of endothelial progenitor cells in the peri-infarct area demonstrating the regenerative capacity of the activated SCF-c-kit pathway in an injured heart. Another study by Yaniz-Galende and colleagues substantiated the above findings by demonstrating that adenovirus-

mediated gene delivery of the membrane-bound form of SCF to the myocardium can provide a long-term improvement in cardiac structure and function in an animal model of myocardial infarction (MI) by the recruitment of cardiac c-kit⁺ population at 1 week post-MI [173]. These reports support the findings of the study presented here and suggest an important role for SCF dependent c-kit activation in promoting the migration and survival of cells that are required for cardiac repair.

The poor survival of the precursor cells can at least in part be attributed to its poor homing capacity affecting the outcome of transplantation cell therapy. Several factors may play a role in determining how efficiently the implanted cell can home to its intended target site. For example, migration of the cells can be affected by the route of administration of the cells. Inefficient migration has been identified as a major problem especially when the cells are delivered via the intracoronary route, as cells must transverse through the endothelial barrier to enter into the interstitial space and migrate towards the infarcted area. In a recent study, our laboratory has shown that greater than 60% of the injected cells are lost during the first 5 min of intracoronary injection of CPCs [34], suggesting that the majority of the cells are immediately washed away by the coronary blood flow. Moreover, during the ensuing 24 hour, greater than 85% of the cells remaining at 5 min are further lost [34]. Such rapid loss of the transplanted cells can be explained, at least in part, by inefficient homing and engraftment of the cells, which represents a major hurdle in the current CPC therapy. One of the findings in the present study is that activation of c-kit by its ligand SCF can stimulate migration/chemotaxis of human patient-derived CPCs. This implies that augmentation of the SCF/c-kit signal pathway represents an attractive mean to enhance CPC homing and engraftment in the context of cardiac cell therapy.

Previous studies have shown that the progenitor cells require a combination of cytokines for optimal growth. For example, a study by Lowry *et al* have shown that SCF in combination with colony-stimulating factor-1 (CSF-1), granulocyte CSF (G-CSF), granulocyte-macrophage CSF (GM-CSF), interleukin -1 α (IL-1 α), and IL-3 stimulated optimal colony growth of the murine hematopoietic progenitor cells [174]. In the same system, addition of SCF or the cytokine cocktail alone did not produce significant colonies suggesting that SCF has the ability to synergize with a combination of growth factors and stimulate the growth of the hematopoietic colonies [174]. Also in another study by Gabilov *et al*, addition of SCF or basic FGF (bFGF) alone to myeloid progenitor cells did not promote its growth. But, when they are added in combination with GM-CSF, the growth of the progenitor cells was significantly increased. The effect was further enhanced when a combination of SCF and bFGF was added to GM-CSF further supporting the synergistic action of SCF with other growth factors [175]. Supported by the synergy of SCF in other progenitor cell populations, I tested if SCF has a combinatorial effect with bFGF or VEGF in augmenting the growth/survival of CPCs. The results of this study indicate that there is no additive effect of SCF with bFGF/VEGF in CPCs implying that these growth factors act through a common signal transduction pathway in CPCs.

The findings of the present study demonstrate that activation of c-kit leads to increased proliferation and survival and induce migration/chemotaxis in human patient-derived CPCs grown under serum depletion. Serum starvation has been demonstrated to affect cell survival and growth by modifying proteins that regulate cell cycle and apoptosis. For example, culturing human ovarian carcinoma cell line under serum depleted conditions was found to arrest the cells in G1 phase of the cell cycle by the suppression of cyclin dependent kinases 2 and 4 (CDK 2, CDK4) that are

required to drive the cells from G1 to the S phase [176]. Interestingly, c-kit activation with SCF was found to release the cells from G1 arrest by upregulating the cell cycle protein cyclin D3 via the PI3K-AKT pathway [134]. The function of cyclin D3 is to phosphorylate and inactivate the retinoblastoma protein (Rb) that prevents the cells from progressing to the S phase [177]. In addition to arresting the cells at G1, serum starvation has been shown to induce apoptosis by enhancing the expression of pro-apoptotic proteins BAX and PUMA [178] or by activating the apoptosis initiator protein, Ataxia telangiectasia mutated (ATM) [179]. In contrast, c-kit activation has been found to upregulate the expression of the anti-apoptotic proteins Bcl-2 and Bcl-X_L [180]. Bcl-2 functions to prevent the activation of the pro-apoptotic protein BAX thereby suppressing programmed cell death [181]. Though the presented study did not test the contribution of these effectors in the SCF-c-kit mediated survival/growth of CPCs, in support of the above discussed studies, it is tempting to speculate a similar mechanism is responsible for the pro-survival/growth response observed after c-kit activation in CPCs cultured in nutrient deprived conditions.

This study also presents that in divergence to its role under serum deprivation, c-kit activation is not sufficient to rescue the cells that are subjected to DMNQ/H₂O₂ induced oxidative stress. Studies in HSCs have shown that ATM and the Forkhead family of transcription factors (FOXO) are essential for the anti-oxidative stress response in progenitor cells. Loss of either of the proteins has been reported to cause accumulation of reactive oxygen species (ROS) resulting in a defective HSC pool leading to marrow failure [182, 183]. Moreover, the activation of certain signaling cascade like the PI3K-AKT pathway phosphorylates and inactivates FOXO transcription factors [184]. In light of the above reports, it is tempting to speculate that the activation of c-kit in CPCs inactivates the FOXO proteins through a similar

mechanism thereby suppressing the anti-oxidative stress response. When the cells are challenged with drug induced oxidative stress in addition to serum starvation, the inherent anti-oxidative stress mechanism may be overwhelmed and not sufficient to protect the cells. It is also possible that the SCF-c-kit signaling cascade may inhibit ATM thereby increasing the sensitivity of CPCs to drug induced oxidative stress.

The cellular effects of c-kit activation upon SCF stimulation are produced by the dimerization and autophosphorylation of the receptor leading to the activation of signal transduction pathways that mediates the biological effects. The findings presented here invite an interesting question about the molecular pathways that are involved in mediating the pro-survival and chemotactic effects of SCF-c-kit axis which is addressed in the next chapter.

In conclusion, with the results of this study it is evident that the activation of the c-kit receptor is involved in regulating proliferation, apoptosis and migration of CPCs. Targeting c-kit to manipulate the properties of CPC has the potential to lead to better treatment strategies and improve the therapeutic outcome of CPC transplantation.

CHAPTER III

MOLECULAR PATHWAYS INVOLVED IN SCF-C-KIT MEDIATED HUMAN CARDIAC PROGENITOR CELL SURVIVAL OR GROWTH AND MIGRATION

Introduction:

The pleiotropic cellular responses of SCF dependent c-kit activation are mediated via the activation of multiple signaling pathways downstream. These pathways include the PI3K-AKT [119, 124], p38MAPK [138, 185], MEK-ERK [139, 141], SFK [141, 186], phospholipase C [187] and JAK/STAT [126, 185] pathways. Among these, the PI3K-AKT and the MEK-ERK pathways often represent the major pathway activated upon c-kit stimulation in a wide variety of cell types [139, 188, 189]. A detailed description of the PI3K-AKT and MEK-ERK pathways is given in the section under signal transduction discussed in Chapter I of this manuscript. Briefly, when the growth receptor is phosphorylated on their intracellular tyrosine domains after ligand binding the PI3K translocates and binds to the receptor directly or indirectly through the receptor substrates via the SH2 domain present in their regulatory subunit. This binding causes allosteric activation of the enzyme which leads to the phosphorylation of PIP2 to PIP3. As discussed earlier, PIP3 can activate AKT initiating the signaling cascade. Similarly, ligand activated growth receptor binds to the adapter protein Grb-2 which binds to SOS. SOS interacts with the membrane bound protein Ras and catalyzes the exchange of Ras bound GDP against GTP. Activated Ras binds to several effector proteins including B-Raf and activates them. B-Raf activates MEK1/2 which in turn phosphorylates and activates

ERK1/2 initiating the signaling cascade [20].

Since the discovery of the c-kit receptor and its ligand SCF, several different gain of function mutations of c-kit that are associated with a number of diseases have been identified. A majority of these mutations involve the residues in the juxtamembrane region or in the second kinase domain [190]. For example, substitution of aspartic acid 816 (in humans) with valine (D816V) is a common gain of function mutation associated with c-kit. This mutation results in an increased kinase activity and constitutive phosphorylation on tyrosine residues independent of ligand binding, leading to cellular transformation [191, 192]. Several studies have reported that such gain of function mutation of c-kit cause constitutive activation of the PI3K-AKT and MEK-ERK pathways, contributing to uncontrolled proliferation and survival of the transformed cells [188, 193]. These pathways are not only involved in tumorigenesis but also found to be the key players in mediating the physiological functions in c-kit⁺ cell types. They are identified to play an important role in regulating the proliferation, migration and survival in melanocytes [36, 194], mast cells [139, 195], endothelial cells [59] and hematopoietic stem cells [196]. It has been reported that these two pathways are dependent on each other and the inhibition of the PI3K-AKT pathway leads to the inhibition of the MEK-ERK pathway, at least in melanocytes [120]. In the same cells, inhibition of these two pathways with pharmacological inhibitors has resulted in cellular apoptosis, indicating the indispensable role of the above two pathways in cell survival [120].

The significance of the activation of any signaling molecule in a cell system can be elucidated using specific pharmacological inhibitors for the molecule. Similarly, pharmacological inhibition of the PI3K-AKT and MEK-ERK pathways can be used to analyze the involvement of these pathways in mediating the cellular

responses. In this study, I used Wortmannin the inhibitor of PI3K and PD98059 the MEK inhibitor to validate the participation of these two pathways downstream of c-kit activation.

Wortmannin is a steroid metabolite isolated from the fungi *Penicillium wortmannii* [197]. It is a specific inhibitor of PI3K at the physiological pH [198]. A detailed description of the PI3K-AKT signaling cascade is given under the signal transduction section of chapter 1. Under physiological pH, Wortmannin binds covalently to p110 subunit of PI3K [198]. However, when the pH is increased to 8.5 and beyond, it could also bind to the regulatory subunit. It was also found to bind non-specifically to other related kinases at micromolar concentration. Substrates of PI3K like PIP2, ATP and ATP analogs were found to effectively compete with Wortmannin for their binding with PI3K, indicating that the binding of Wortmannin to the PI3K involves the ATP binding pocket. Site directed mutagenesis study by Wymann *et al* confirmed that the inhibition of PI3K by Wortmannin is mediated through the covalent modification of a critical lysine residue (Lys-802) involved in the transfer of phosphate moiety from ATP to the substrate of PI3K [198].

As discussed earlier, activation of the MEK-ERK pathway requires the phosphorylation of ERK1/2 on a threonine and a tyrosine residue simultaneously, by MEK1/2, a dual specificity kinase [199]. MEK 1 and 2 are the two isoforms of MEK and share approximately 85% sequence similarity [200]. Dudley *et al* identified and demonstrated that the synthetic inhibitor, PD98059 [2-(29-amino-39-methoxyphenyl)-oxanaphthalen-4-one], can effectively inhibit MEK1/2 thereby preventing the downstream activation of ERK1/2 and other substrates of the MEK-ERK pathway [201]. The effective inhibition of the MEK-ERK pathway resulted in the phenotype reversal of the transformed mouse fibroblast and rat kidney cells [201]. Studies have

shown that PD98059 is specific for MEK1/2 inhibition and it does not affect the kinase activity of ERK1/2 or other cellular kinases [201]. Mechanistically, it is a non-competitive inhibitor of MEK1/2. Binding of PD98059 to MEK inhibits the phosphoryl transfer from ATP to ERK1/2 by an allosteric mechanism [201]. Such a non-ATP competitive mechanism was found to enhance the selectivity of this inhibitor over the ATP-mimetic inhibitors.

Although the PI3K and the MAPK pathways are found to be important in mediating the downstream effects of SCF dependent c-kit stimulation in various cell types as discussed earlier, the role of these signaling pathways in regulating the survival, growth and migration of CPCs is completely unknown. Hence in this study, I tested if the pathways are activated upon c-kit activation and confirmed the involvement of these pathways in regulating the survival, growth and migration of CPCs using Wortmannin and PD98059. The findings of this study indicate that the PI3K-AKT and MEK-ERK pathways are activated upon c-kit activation and are essential for the survival or growth and migration of CPCs. A schematic representation of this chapter is given in Figure 15.

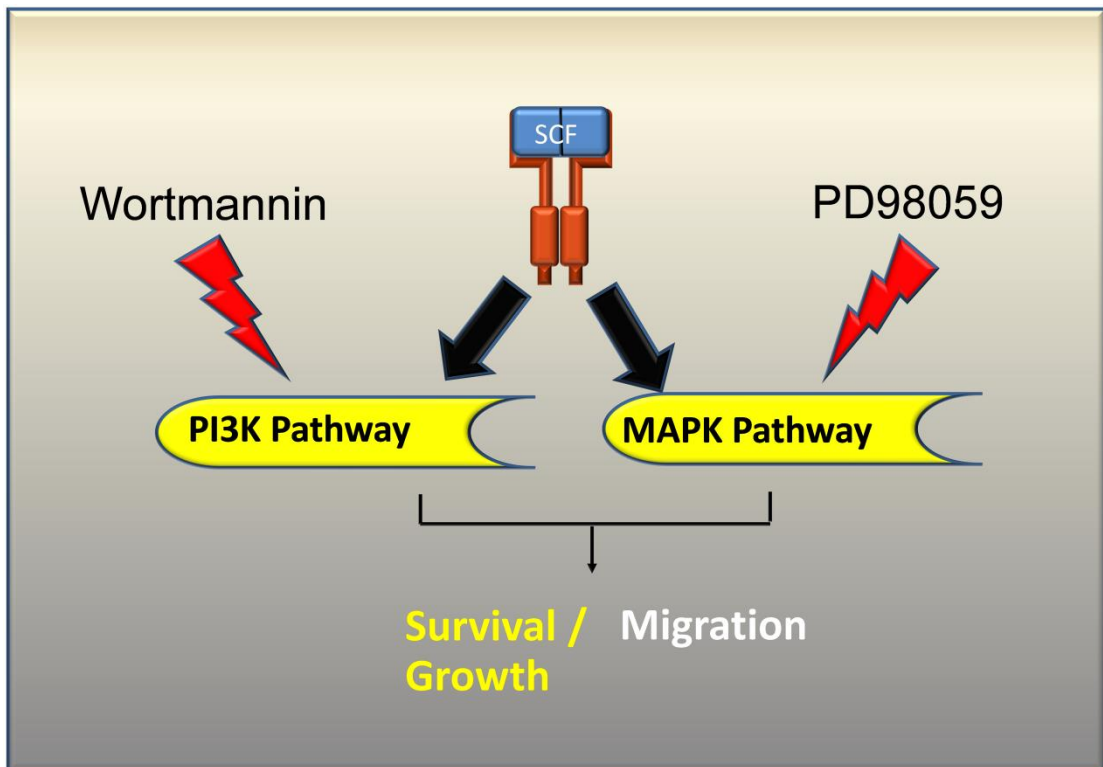

Figure 15: **Schematic illustration of chapter III.** Activation of the c-kit receptor by the ligand SCF leads to the autophosphorylation of critical tyrosine residues and leads to the activation of the PI3K-AKT and MEK-ERK pathways, confirmed by Western blot analysis. Inhibition of either or both the PI3K-AKT pathway with Wortmannin (PI3K inhibitor) or the MEK-ERK pathway with PD98059 (MEK inhibitor) resulted in the suppression of survival and migration of CPCs after c-kit activation.

Materials and Methods:

Western blot:

Refer to methods and materials section in chapter II. Primary antibodies used were anti-c-kit (1 in 500; abcam #32363), anti-phospho c-kit (Y703; 1 in 500; Cell signaling #3073P), anti-AKT (1 in 1000; Cell signaling # 4691), anti-phospho AKT (Thr 308; 1 in 1000; Cell signaling # 13038), anti-ERK1/2 (1 in 1000; Cell signaling # 4695P), anti-phospho ERK1/2 (1 in 1000; Cell signaling # 4370P), alpha-tubulin (1 in 3000; Sigma Aldrich # T6074).

PI3K and MEK inhibitors

Wortmannin and PD98059 were purchased from Cell Signaling Technology and used at 200 nM and 40 μ M concentrations, respectively. For the Western blot analysis, CPCs were serum starved for 24 hours and pre-treated with the inhibitors for 2 hr followed by 20 min of SCF (100 ng/ml) treatment. For the cell viability and migration assays, cells were pre-treated with the indicated inhibitors for 2 hours prior to being treated with SCF.

Results:

PI3K and MAPK pathways mediate the pro-growth and chemotactic effects of SCF/c-kit on CPCs

A schematic representation of our experiments is given in Figure 16. First I examined if the PI3K-AKT and the MEK-ERK pathways are activated upon c-kit activation. I treated the CPCs with 100 ng/ml of SCF for varying duration from 5 minutes up to 60 minutes and analyzed the changes in the phosphorylated (i.e., activated) AKT and phosphorylated ERK levels by Western blot. I found a significant increase in the level of phosphorylated AKT within 10 min after SCF treatment, while

the phosphorylated ERK levels increased as early as 5 min of SCF treatment (Figure 17). These results suggest that both the PI3K-AKT and MEK-ERK pathways are indeed activated upon c-kit activation in CPCs. In order to understand the contribution of each of these pathways to the biological effects of SCF/c-kit signaling on CPCs, I utilized wortmannin, and PD98059 to inhibit the PI3K-AKT and the MEK-ERK pathways, respectively. As shown in Figure 18, Western blot analysis confirmed that both inhibitors were effective in down-regulating their corresponding pathways, indicated by a significant reduction in the levels of activated AKT or activated ERK in cells co-treated with SCF and the inhibitors. Interestingly, inhibition of the MEK-ERK pathway also inhibited the PI3K-AKT pathway but not vice versa (Figure 18), suggesting that MEK-ERK pathway operates upstream of the PI3K-AKT pathway.

As a next step, to test the participation of the PI3K-AKT and MEK-ERK pathways in the survival or growth and migration of CPCs, I pre-treated them with these inhibitors (i.e., Wortmannin and PD98059) either individually or in combination. While treating the cells with inhibitors alone did not affect their cell numbers, I found that the inhibitor pre-treatment abolished the pro-survival/growth effect of SCF when the CPCs were cultured under serum starvation (Figure 19A). I then tested if the pro-migratory effect of SCF is also dependent on PI3K-AKT and/or MEK-ERK pathways. While SCF alone stimulated cell migration (as shown earlier), pre-treatment of the cells with either one of the inhibitors or in combination, prior to the SCF treatment prevented CPCs from migrating towards the SCF gradient (Figure 19B). These results strongly suggest that the PI3K-AKT and the MEK-ERK pathways are the major pathways that regulate both pro-survival/growth and migratory effects of c-kit activation in human CPCs.

A

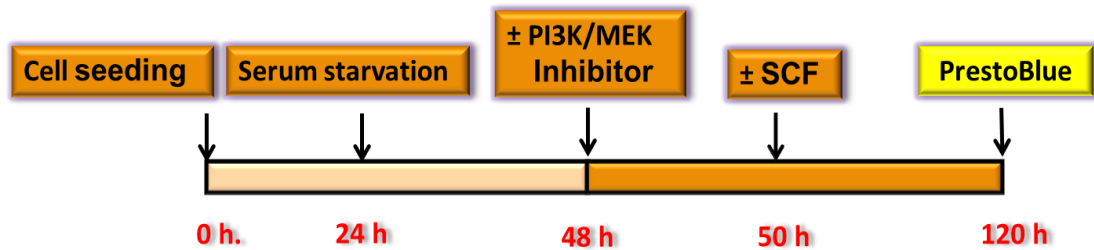

B

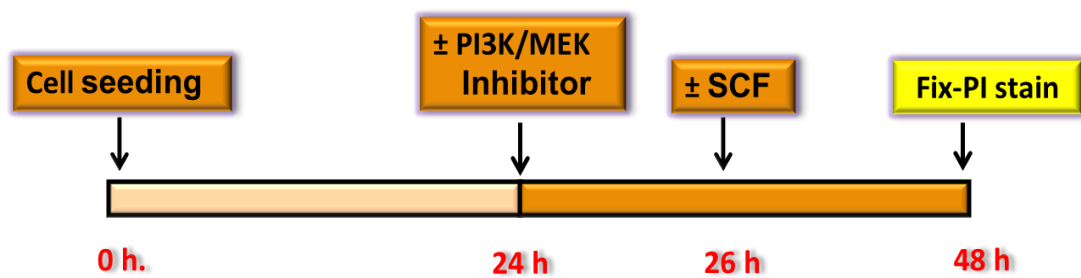

Figure 16: **Schematic representation of chapter III experimental approach.**

Investigating the mechanism of c-kit activation in mediating the survival, growth and migration of CPCs. A. Pharmacological inhibition of the PI3K-AKT and MAPK pathways. CPCs will be treated with inhibitors separately or in combination two hours before SCF treatment and harvested for cell viability assay at the indicated time point. B. CPC migration. CPCs will be treated with inhibitors separately or in combination two hours before adding SCF as a chemoattractant and the number of cells migrated are analyzed at the indicated time point.

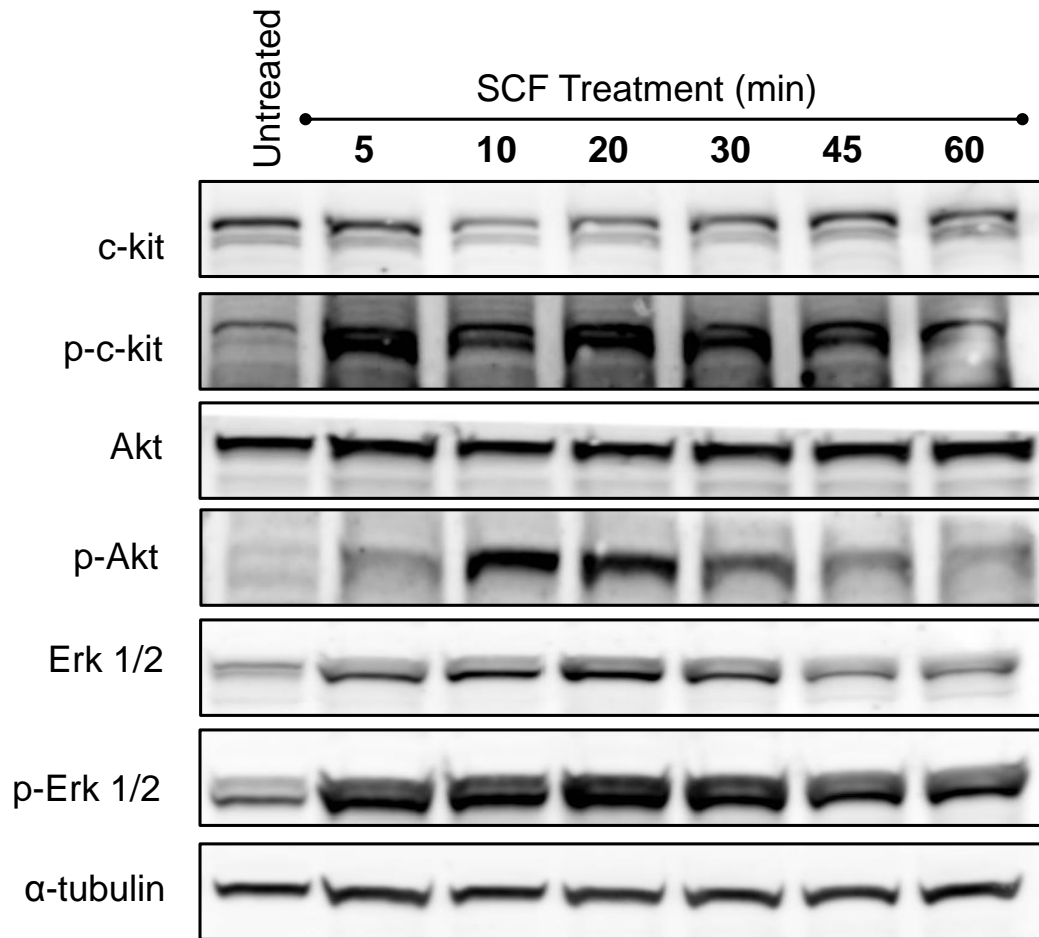

Figure 17: **SCF dependent c-kit stimulation activates the PI3K-AKT and MEK-ERK1/2 pathways.** Human CPCs were either untreated or treated with 100 ng/ml SCF for increasing duration. Activation of the pathways was determined by immunoblotting (n=1).

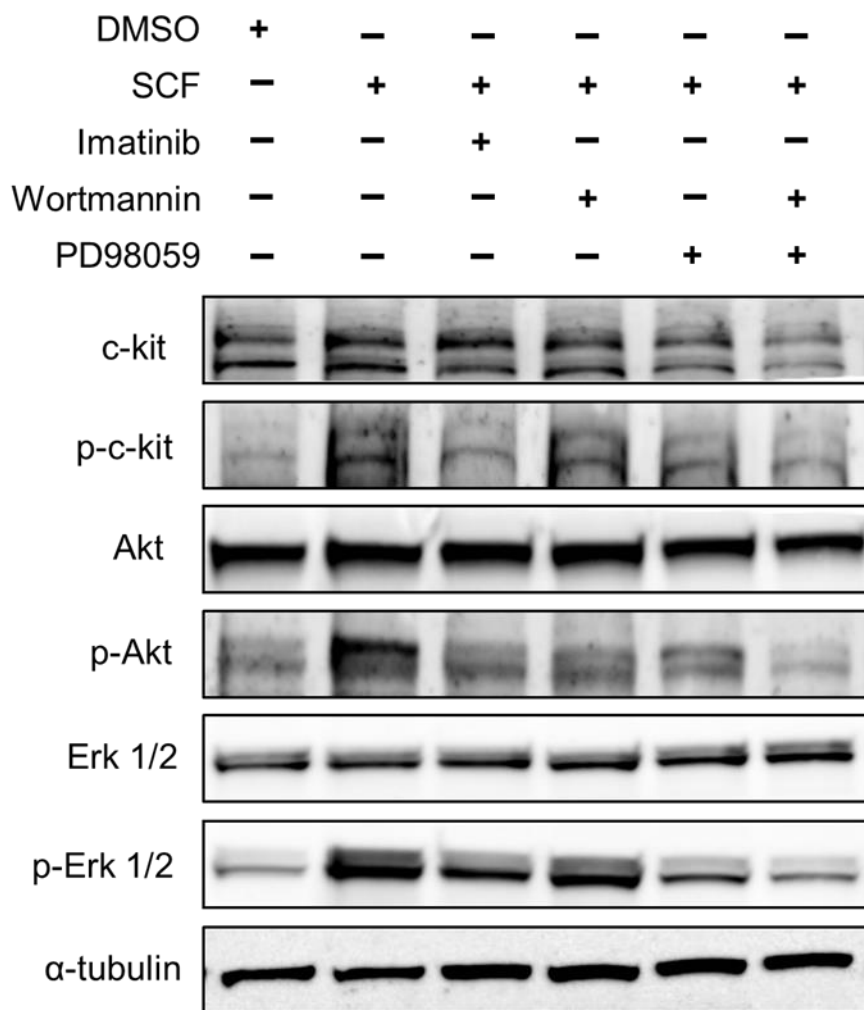
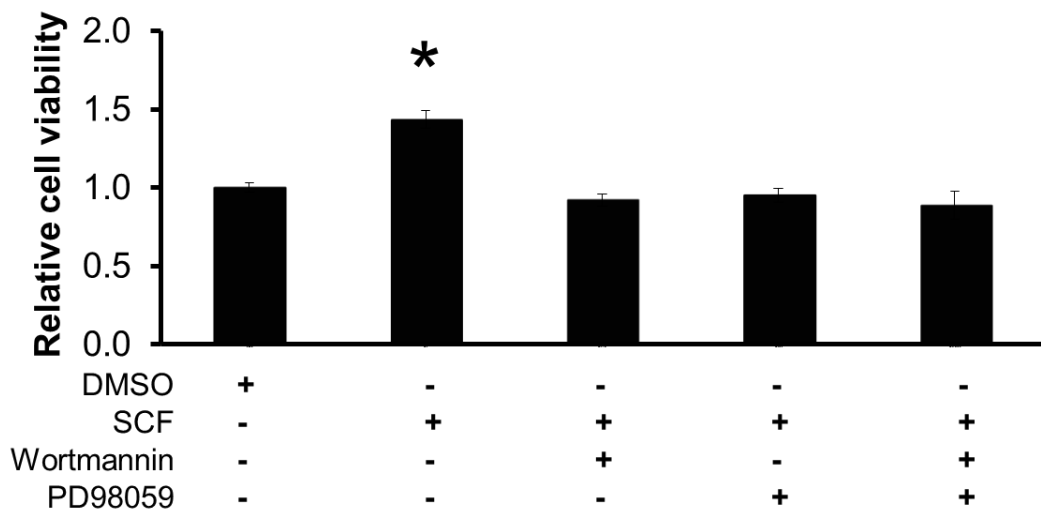
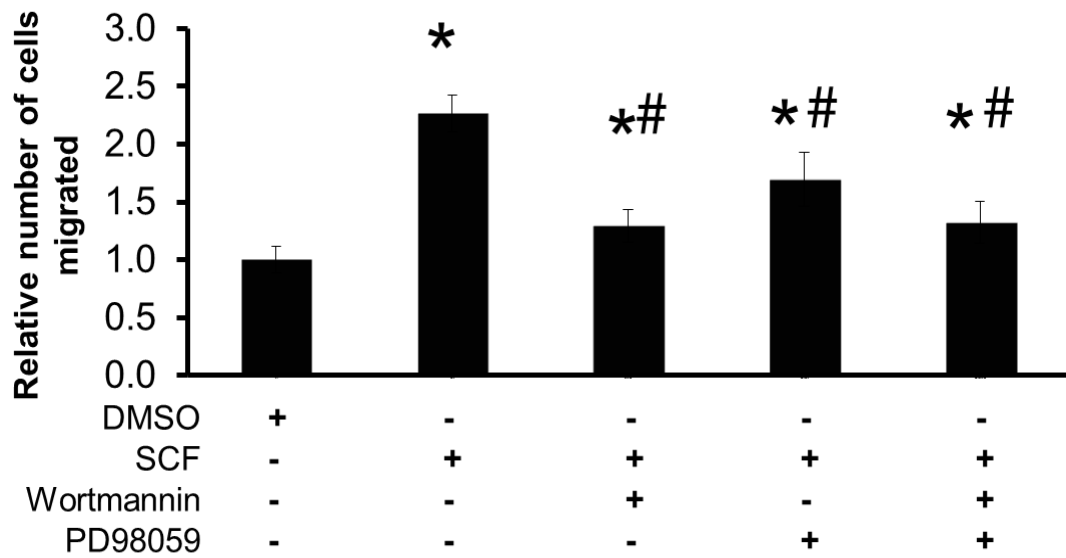

Figure 18: **Inhibition of the PI3K-AKT and MEK-ERK1/2 pathways with the inhibitors, Wortmannin (PI3K inhibitor) and PD98059 (MEK inhibitor).** CPCs were pre-treated with the inhibitors for 2 hours followed by SCF (100 ng/ml) mediated c-kit stimulation for 20 minutes. Cells were harvested using laemlli sample buffer and immunoblotted (n=1).

A



B



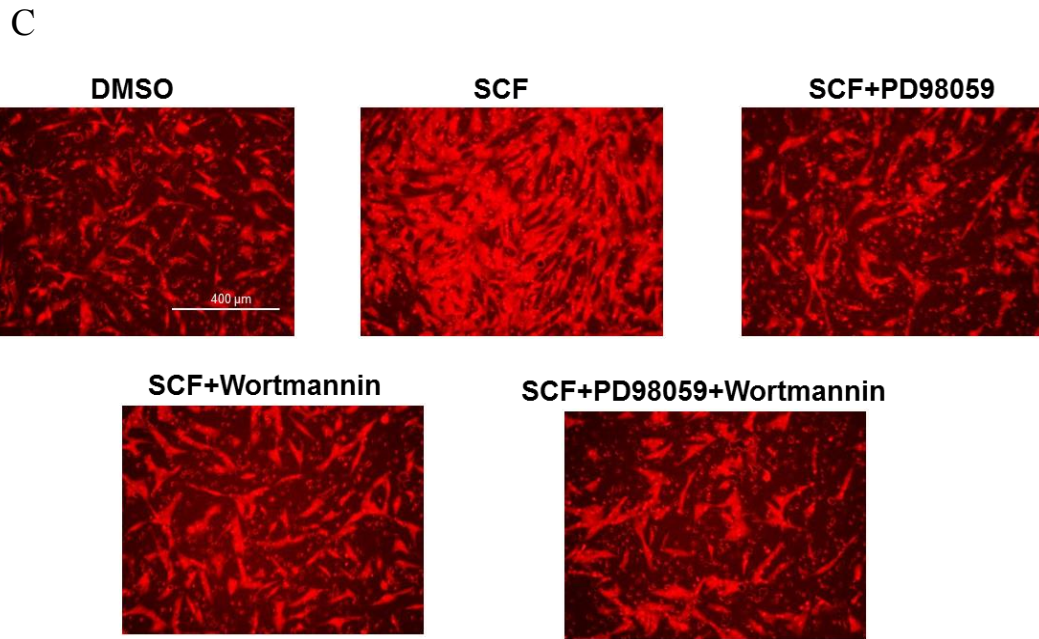

Figure 19: **Pro-survival and chemotactic effect of SCF was abolished by pre-treatment with inhibitors.** CPCs were serum starved for 24 hours and pre-treated with 200 nM Wortmannin (PI3K inhibitor) or 40 μ M PD98059 (MEK inhibitor) for 2 hours, followed by SCF treatment. A, The pro-survival effect observed under serum starvation upon SCF dependent c-kit stimulation was abolished with inhibitors pre-treatment. Viability was assessed 3 days post-SCF treatment using prestoblue (n=3). B, 24 hours after plating CPCs on the transwells, they were pre-treated with the inhibitors for 2 hours followed by replenishing the media in the lower chamber with or without SCF. CPCs were fixed with 3.7% formaldehyde 24 hours later and stained with propidium iodide (n=2). C, Representative images of B. All values are normalized to the untreated control. All experiments were done in quadruplicates. Values are presented as mean \pm SE. *, p<0.05 compared to the DMSO control, #, p<0.05 compared to SCF.

Discussion:

Here, I identified for the first time the growth/survival and migration of CPCs are regulated by c-kit through the activation of the PI3K-AKT and MEK-ERK pathways. Firstly, I demonstrated the activation of the above two pathways after SCF mediated c-kit stimulation. Secondly, pharmacological inhibition of these pathways reduced the viability and chemotaxis of CPCs. This indicates that the PI3K-AKT and MEK-ERK are the major pathways mediating the survival/growth and migration of CPCs upon c-kit activation. The findings of this study are well supported by the reports published by other investigators on the role of PI3K-AKT and MEK-ERK pathways in several c-kit⁺ cell types. For example, Haneline *et al* have shown that genetic inactivation of the regulatory subunit (p85) of PI3K affects the survival and proliferation of erythroid and myeloid progenitors [202]. The study reported that mouse fetal liver deficient in p85 had significantly lesser erythroid and myeloid progenitors compared to the wild type control. Additionally, upon stimulation with SCF, the p85 deficient progenitor cells were found to have a significantly lesser rate of proliferation when compared to the p85 sufficient cells [202], indicating the pro-growth/survival effect of this pathway. Moreover, SCF treatment activated the MEK-ERK pathway that was found to be essential for the proliferation and expansion of erythroid progenitors [203]. The study demonstrated that the treatment of serum starved erythroid progenitors with a combination of SCF and erythropoietin (Epo) induced activation of the MEK-ERK pathway, identified by immunoblotting. Furthermore, the SCF-Epo combination synergistically increased the number and size of the erythroid colonies. Inhibition of the MEK-ERK pathway with the MEK inhibitor PD98059 abolished the pro-growth effect of SCF-Epo combination further supporting the requirement of this pathway for erythropoiesis. Taken together, the

above results support the essential role of the PI3K-AKT and MEK-ERK pathways in regulating the survival/growth in progenitor cell population.

Besides steady state conditions, SCF/c-kit signaling cascade is often activated and plays a vital role in various tissue injury conditions also [204-206]. For instance, Sun and colleagues have shown that SCF-c-kit axis is critical for the recruitment of progenitor cells to the injury site [204]. The authors introduced cryoinjury in a mouse brain model and observed a significant increase in SCF mRNA and protein levels at the injury site [204]. Microscopic analysis of the stained sections revealed that the induction of SCF expression occurred in the cells that are adjacent to the site of injury and the level of expression reduced with an increase in the distance from the injured area. The authors also established that SCF can induce the migration and recruitment of the c-kit⁺ neuronal stem cells *in vitro* and *in vivo*. Taken together, this study suggests a role for SCF-c-kit axis in mediating the migration of progenitor cells to the site of injury [204]. Corroborating the above findings, Lutz and co-workers showed that local intramyocardial injection of SCF improves myocardial homing of systemically delivered c-kit⁺ bone marrow-derived stem cells [11]. From the results of these studies, it is clear that SCF-c-kit signaling has an essential role in the mobilization and migration of c-kit⁺ progenitor cells to the wounded area and support regeneration [91, 207-209]. Interestingly, it was found that following cardiac injury, the membrane-bound form of SCF is cleaved by MMP-9 and released within bone marrow, facilitating the mobilization of bone marrow progenitor cells through the activation of c-kit [91, 95]. Adding more support to this notion, the mobilization of bone marrow-derived progenitor cells and their recruitment to the injured heart are severely compromised in the c-kit mutant (*Kit^W/Kit^{W-v}*) mouse [91], establishing that activation of c-kit is indeed necessary for homing of the bone marrow-derived

progenitor cells. In line with the above findings, the data presented here establishes that the SCF-c-kit axis induces the migration of CPCs by activating the PI3K-AKT and MEK-ERK pathways.

In addition to its function as a chemotactic signal to recruit c-kit⁺ bone marrow progenitor cells, SCF also promotes adhesion of the recruited cells which is required for its homing to the injury site. For instance, activation of c-kit by SCF enhances the adhesion of c-kit⁺ bone marrow cells to fibronectin as well as to the activated vascular smooth muscle cells following vascular injury [208]. The adhesion was completely blocked by anti-SCF antibody. These observations suggest that SCF/c-kit signaling not only provides a chemotactic signal to recruit c-kit⁺ progenitors to the injury site, but also facilitates their engraftment. Although we have not examined whether activation of SCF/c-kit signaling can also promote adhesion of CPCs either to endothelium or injured myocardium, it is tempting to speculate that SCF/c-kit signaling also positively contributes to adhesion and engraftment of the transplanted c-kit⁺ CPCs to the injury areas in the setting of regenerative cardiac cell therapy.

An interesting finding of the presented study is that the inhibition of the MEK-ERK pathway also inhibited the PI3K-AKT pathway but not vice versa. This indicates that at least in CPCs, MEK-ERK functions upstream of PI3K-AKT. Although this is contrary to what was observed in melanocytes [120] where the inhibition of the PI3K-AKT pathway with Wortmannin suppressed the activation of the MEK-ERK pathway, it supports the dependency of the pathways on each other and substantiates a similar role played by these two pathways in regulating the cellular responses in various c-kit positive cell types. While this study compared only the number of cells; treated and untreated with SCF; that survived at the end of 3 days in serum depletion conditions,

it has not tested the contribution of each of these pathways to CPC proliferation and apoptosis in particular. As this study evidenced the MEK-ERK pathway and the PI3K-AKT pathway shares a common signaling mechanism, it is very likely that the inhibition of one or both the pathways will equally affect growth and survival of CPCs. In order to confirm this, the proliferation and apoptosis of CPCs following c-kit activation has to be measured after inhibition of the PI3K-AKT and/or MEK-ERK pathways. Also as discussed below it is essential to determine the downstream mediators of these pathways that are activated after c-kit stimulation to understand if any of them mediates predominantly a pro-survival or anti-apoptotic function.

Although this study identified the involvement of the PI3K-AKT and MEK-ERK pathway in regulating the migration, survival/growth of CPCs, the downstream effectors of either of the pathways are not explored. Phosphorylation of AKT and ERK1/2 has been known to regulate a plethora of downstream mediators. For example phosphorylation of AKT on its serine and threonine residues regulates several proteins including pro-apoptotic proteins, Bcl-2-associated death promoter (BAD) [111] and FOXO [133], proteins that regulate protein synthesis like mTOR and ribosomal protein S6 kinase [134, 135], proteins that regulate cellular proliferation, migration, glucose synthesis like GSK3 β [146]. Intriguingly, SCF dependent c-kit activation was found to phosphorylate and inactivate BAD in a PI3K-AKT dependent manner, thereby preventing its interaction with the anti-apoptotic protein Bcl-2 [111]. Free Bcl-2 inhibits cytochrome c release and hence the caspase cascade thereby inhibiting apoptosis. Also SCF-c-kit axis has been indicated to promote the proliferation through the upregulation of the ribosomal protein S6 kinase (pS6K) via the activation of the PI3K-AKT pathway in germ cells [134]. pS6K induces the expression of the cell cycle regulating protein cyclin D3 and thus

promotes proliferation of cells. These evidences suggest that the pro-growth/survival effect mediated by the c-kit activated PI3K-AKT pathway in CPCs may involve one or more of the effectors mentioned above. Similar to AKT, ERK1/2 phosphorylation can regulate proteins such as the retinoblastoma protein (Rb) [210], microphthalmia associated transcription factor (MITF) [37], c-fos, c-jun, etc. For example ERK1/2, has been shown to phosphorylate and increase the activity of MITF which functions to regulate the expression of genes that are essential for the proliferation and survival of cells [211, 212]. Also treating the cells with SCF significantly upregulated the expression of MITF and hence the proliferation in mast cells supporting the pro-growth effect of SCF-c-kit signaling. Altogether the above reports support the implication that these signaling molecules downstream of AKT and ERK1/2 activation play a role in regulating cell cycle, protein synthesis and apoptosis in CPCs.

Correspondingly, the migration of CPCs mediated by the PI3K-AKT and MEK-ERK can involve different downstream mediators. Migration studies in COS-7 cells have shown that ERK1/2 phosphorylates and activates the myosin light chain kinase (MLCK) protein which in turn phosphorylates myosin light chain (MLC) [213]. Phosphorylation of MLC favors its interaction with actin promoting contraction of the cytoskeleton and cellular migration. Another study by Jeon *et al* has shown that SCF treatment of melanocytes can activate the PI3K-AKT and cause the phosphorylation of a group of proteins called ERM proteins (Ezrin, Radixin, Moesin) [194]. Phosphorylation of the ERM proteins is found to be essential in initiating actin polymerization and cell migration [213]. In light of the above reports, to have a better understanding of the SCF-c-kit mediated pro-growth/survival and chemotactic effects, it is essential to investigate the activation and specific role of these downstream effectors after the stimulation of the PI3K-AKT and MEK-ERK cascade.

In summary, I demonstrated that the PI3K-AKT and the MEK-ERK pathways are activated upon SCF dependent c-kit activation and play a role in regulating the survival/growth and migration of CPCs. Biological function of these pathways activated upon c-kit stimulation in CPCs are inter dependent on each other with the MEK-ERK acting upstream of the PI3K-AKT.

Conclusion and Future Directions:

With the results of this study I demonstrated that c-kit with its ligand SCF is a key regulator of survival, growth and migration of CPCs. Although the study could not establish a relationship between c-kit activation and differentiation of CPCs, it informed that CPCs are partially differentiated by culturing them in the differentiation media for a longer duration and the dexamethasone dependent differentiation protocol has to be optimized to implement on CPCs. Mechanistically, my study also demonstrated the activation of the PI3K-AKT and MEK-ERK pathways downstream of c-kit activation and its vitality in promoting the survival/growth and migration of CPCs.

The current data directs a series of future experiments that would aid in a better understanding on the role of c-kit and CPCs in cardiac regeneration. As discussed before, these cells provide significant therapeutic benefit besides their poor survival *in vivo* indicating a paracrine effect. It will be interesting to elucidate the release of any pro-growth/survival cytokines by CPCs and if the expression of c-kit has any role in regulating the secretory function of CPCs. As our laboratory has identified the expression of SCF by these cells (data not shown), it will be a wise start to ascertain the relationship between the expression of the c-kit receptor and its ligand to identify the presence of a feedback loop regulating their function. For this purpose,

the conditioned media in which the CPCs are grown can be collected and used to culture cardiomyocytes, smooth muscle cells, endothelial cells and fibroblasts followed by measuring their cellular properties. The concentrated and conditioned medium can be subjected to mass spectrometry to identify any released growth factor. Similarly, the contribution of the niche cells to the survival, growth and migration of CPCs is not known. To identify this, co-culturing CPCs with cardiomyocytes, endothelial cells or fibroblasts will be a useful system to recognize the existence and effect of juxtacrine and/or the paracrine signaling mechanisms exchanged between the cells on the growth and survival of CPCs.

Constitutively active c-kit mutants have been implicated to cause uncontrolled proliferation in other c-kit positive cell types like the mast cells and HSCs [188, 214]. However, there is no information on the role of c-kit mutants in CPCs. As the presented study is the first attempt to characterize the role of c-kit protein in CPCs, future experiments to explore the role of c-kit mutants in the growth, survival and migration of CPCs may lead to methods optimizing the survival and/or growth of CPCs. For example, supposing the CPCs function through the paracrine effect, overexpressing the mutant c-kit may lead to more proliferation and prolonged survival of these cells *in vivo* enhancing the paracrine signaling. Also as mentioned earlier, it will be informative to analyze the induction of the pro-growth/survival effectors that are involved downstream of AKT and ERK using quantitative PCR and Western blot to delineate the specific role of each signaling pathway. In the same line, exploring the key players of migration downstream of AKT and ERK, like the ERM proteins, MLCK will help to find mechanisms that synergize with SCF-c-kit axis.

It is meaningful to check for the activation of other molecular pathways like the Src Family kinase pathway [124] and Wnt- β catenin pathways [173] that are

implicated to function in other c-kit⁺ cell types. Such an effort may lead to the finding of proteins that have more than one role in CPCs or that can be activated by more than one pathway. Also, discovery of other signaling mechanism in CPCs may guide to the discovery of growth factors that can synergize with SCF to further promote its cellular response. In the study presented here, I did not measure the ROS generation directly after serum starvation or drug induced oxidative stress. Designing experiments to measure the same in the presence or absence of c-kit activation will provide more information about the anti-oxidative role of SCF-c-kit signaling. Comparing the expression of different anti-oxidant enzymes like the catalase, superoxide dismutase, glutathione peroxidase in CPCs in contrast to other progenitors like the HSCs will help to identify the relative sensitivity of CPCs to oxidative stress induced by different ROS. Similarly, the deleterious effects and mechanistic aspects of serum starvation on CPCs can be tested by checking for the temporal expression of cell cycle and pro-apoptotic proteins with an increasing duration of serum depletion.

It is critical to validate the *in vitro* findings of this study in an *in vivo* model. For this purpose, genetically engineered CPCs with low and high c-kit expression can be infused via the intracoronary and/or intramyocardial route in an animal model of MI. This will be followed by analyzing the growth, survival and migration of the infused cells at serial time points. Additionally, the regeneration of the injured myocardium, cardiomyogenesis, angiogenesis, functional improvement and survival of the animal in different groups can be compared. The results of the *in vivo* study will further corroborate c-kit as a target to promote the survival, growth and homing of CPCs leading to better treatment strategies.

REFERENCES

1. Beltrami, A.P., et al., Evidence that human cardiac myocytes divide after myocardial infarction. *N Engl J Med*, 2001. 344(23): p. 1750-7.
2. Quaini, F., et al., Chimerism of the transplanted heart. *N Engl J Med*, 2002. 346(1): p. 5-15.
3. Bergmann, O., et al., Evidence for cardiomyocyte renewal in humans. *Science*, 2009. 324(5923): p. 98-102.
4. Beltrami, A.P., et al., Adult cardiac stem cells are multipotent and support myocardial regeneration. *Cell*, 2003. 114(6): p. 763-76.
5. Linke, A., et al., Stem cells in the dog heart are self-renewing, clonogenic, and multipotent and regenerate infarcted myocardium, improving cardiac function. *Proc Natl Acad Sci U S A*, 2005. 102(25): p. 8966-71.
6. Bolli, R., et al., Cardiac stem cells in patients with ischaemic cardiomyopathy (SCIPIO): initial results of a randomised phase 1 trial. *Lancet*, 2011. 378(9806): p. 1847-57.
7. Bearzi, C., et al., Human cardiac stem cells. *Proc Natl Acad Sci U S A*, 2007. 104(35): p. 14068-73.
8. Tallini, Y.N., et al., c-kit expression identifies cardiovascular precursors in the neonatal heart. *Proc Natl Acad Sci U S A*, 2009. 106(6): p. 1808-13.
9. Matsuura, K., et al., Adult cardiac Sca-1-positive cells differentiate into beating cardiomyocytes. *J Biol Chem*, 2004. 279(12): p. 11384-91.
10. Wang, X., et al., The role of the sca-1+/CD31- cardiac progenitor cell population in postinfarction left ventricular remodeling. *Stem Cells*, 2006. 24(7): p. 1779-88.

11. Oh, H., et al., Cardiac progenitor cells from adult myocardium: homing, differentiation, and fusion after infarction. *Proc Natl Acad Sci U S A*, 2003. 100(21): p. 12313-8.
12. Hierlihy, A.M., et al., The post-natal heart contains a myocardial stem cell population. *FEBS Lett*, 2002. 530(1-3): p. 239-43.
13. Pfister, O., et al., CD31- but Not CD31+ cardiac side population cells exhibit functional cardiomyogenic differentiation. *Circ Res*, 2005. 97(1): p. 52-61.
14. Oyama, T., et al., Cardiac side population cells have a potential to migrate and differentiate into cardiomyocytes in vitro and in vivo. *J Cell Biol*, 2007. 176(3): p. 329-41.
15. Messina, E., et al., Isolation and expansion of adult cardiac stem cells from human and murine heart. *Circ Res*, 2004. 95(9): p. 911-21.
16. Smith, R.R., et al., Regenerative potential of cardiosphere-derived cells expanded from percutaneous endomyocardial biopsy specimens. *Circulation*, 2007. 115(7): p. 896-908.
17. Johnston, P.V., et al., Engraftment, differentiation, and functional benefits of autologous cardiosphere-derived cells in porcine ischemic cardiomyopathy. *Circulation*, 2009. 120(12): p. 1075-83, 7 p following 1083.
18. Laugwitz, K.L., et al., Postnatal isl1+ cardioblasts enter fully differentiated cardiomyocyte lineages. *Nature*, 2005. 433(7026): p. 647-53.
19. Bu, L., et al., Human ISL1 heart progenitors generate diverse multipotent cardiovascular cell lineages. *Nature*, 2009. 460(7251): p. 113-7.
20. Ellison, G.M., et al., Adult c-kit(pos) cardiac stem cells are necessary and sufficient for functional cardiac regeneration and repair. *Cell*, 2013. 154(4): p. 827-42.
21. Leri, A., J. Kajstura, and P. Anversa, Cardiac stem cells and mechanisms of myocardial regeneration. *Physiol Rev*, 2005. 85(4): p. 1373-416.
22. Urbanek, K., et al., Stem cell niches in the adult mouse heart. *Proc Natl Acad Sci U S A*, 2006. 103(24): p. 9226-31.

23. Jalali, S., et al., Integrin-mediated mechanotransduction requires its dynamic interaction with specific extracellular matrix (ECM) ligands. *Proc Natl Acad Sci U S A*, 2001. 98(3): p. 1042-6.
24. Sanada, F., et al., c-Kit-positive cardiac stem cells nested in hypoxic niches are activated by stem cell factor reversing the aging myopathy. *Circ Res*, 2014. 114(1): p. 41-55.
25. Dawn, B., et al., Cardiac stem cells delivered intravascularly traverse the vessel barrier, regenerate infarcted myocardium, and improve cardiac function. *Proc Natl Acad Sci U S A*, 2005. 102(10): p. 3766-71.
26. Miyamoto, S., et al., Characterization of long-term cultured c-kit⁺ cardiac stem cells derived from adult rat hearts. *Stem Cells Dev*, 2010. 19(1): p. 105-16.
27. van Berlo, J.H., et al., c-kit⁺ cells minimally contribute cardiomyocytes to the heart. *Nature*, 2014. 509(7500): p. 337-41.
28. Schmidt-Supprian, M. and K. Rajewsky, Vagaries of conditional gene targeting. *Nat Immunol*, 2007. 8(7): p. 665-8.
29. Cheng, K., et al., Relative roles of CD90 and c-kit to the regenerative efficacy of cardiosphere-derived cells in humans and in a mouse model of myocardial infarction. *J Am Heart Assoc*, 2014. 3(5): p. e001260.
30. Tang, X.L., et al., Intracoronary administration of cardiac progenitor cells alleviates left ventricular dysfunction in rats with a 30-day-old infarction. *Circulation*, 2010. 121(2): p. 293-305.
31. Ellison, G.M., et al., Endogenous cardiac stem cell activation by insulin-like growth factor-1/hepatocyte growth factor intracoronary injection fosters survival and regeneration of the infarcted pig heart. *J Am Coll Cardiol*, 2011. 58(9): p. 977-86.
32. Hayashi, M., et al., Comparison of intramyocardial and intravenous routes of delivering bone marrow cells for the treatment of ischemic heart disease: an experimental study. *Cell Transplant*, 2004. 13(6): p. 639-47.
33. Freyman, T., et al., A quantitative, randomized study evaluating three methods of mesenchymal stem cell delivery following myocardial infarction. *Eur Heart J*, 2006. 27(9): p. 1114-22.

34. Hong, K.U., et al., c-kit⁺ Cardiac stem cells alleviate post-myocardial infarction left ventricular dysfunction despite poor engraftment and negligible retention in the recipient heart. *PLoS One*, 2014. 9(5): p. e96725.
35. Yee, N.S., I. Paek, and P. Besmer, Role of kit-ligand in proliferation and suppression of apoptosis in mast cells: basis for radiosensitivity of white spotting and steel mutant mice. *J Exp Med*, 1994. 179(6): p. 1777-87.
36. Botchkareva, N.V., et al., SCF/c-kit signaling is required for cyclic regeneration of the hair pigmentation unit. *FASEB J*, 2001. 15(3): p. 645-58.
37. Hemesath, T.J., et al., MAP kinase links the transcription factor Microphthalmia to c-Kit signalling in melanocytes. *Nature*, 1998. 391(6664): p. 298-301.
38. Mintz, B. and E.S. Russell, Gene-induced embryological modifications of primordial germ cells in the mouse. *J Exp Zool*, 1957. 134(2): p. 207-37.
39. Manova, K. and R.F. Bachvarova, Expression of c-kit encoded at the W locus of mice in developing embryonic germ cells and presumptive melanoblasts. *Dev Biol*, 1991. 146(2): p. 312-24.
40. Cosgun, K.N., et al., Kit Regulates HSC Engraftment across the Human-Mouse Species Barrier. *Cell Stem Cell*, 2014. 15(2): p. 227-238.
41. Yarden, Y., et al., Human proto-oncogene c-kit: a new cell surface receptor tyrosine kinase for an unidentified ligand. *EMBO J*, 1987. 6(11): p. 3341-51.
42. Sherr, C.J., et al., The c-fms proto-oncogene product is related to the receptor for the mononuclear phagocyte growth factor, CSF-1. *Cell*, 1985. 41(3): p. 665-76.
43. Coussens, L., et al., Tyrosine kinase receptor with extensive homology to EGF receptor shares chromosomal location with neu oncogene. *Science*, 1985. 230(4730): p. 1132-9.
44. Chabot, B., et al., The proto-oncogene c-kit encoding a transmembrane tyrosine kinase receptor maps to the mouse W locus. *Nature*, 1988. 335(6185): p. 88-9.

45. Huang, E., et al., The hematopoietic growth factor KL is encoded by the Sl locus and is the ligand of the c-kit receptor, the gene product of the W locus. *Cell*, 1990. 63(1): p. 225-33.
46. Zsebo, K.M., et al., Stem cell factor is encoded at the Sl locus of the mouse and is the ligand for the c-kit tyrosine kinase receptor. *Cell*, 1990. 63(1): p. 213-24.
47. Copeland, N.G., et al., Mast cell growth factor maps near the steel locus on mouse chromosome 10 and is deleted in a number of steel alleles. *Cell*, 1990. 63(1): p. 175-83.
48. Lux, M.L., et al., KIT extracellular and kinase domain mutations in gastrointestinal stromal tumors. *Am J Pathol*, 2000. 156(3): p. 791-5.
49. Longley, B.J., M.J. Reguera, and Y. Ma, Classes of c-KIT activating mutations: proposed mechanisms of action and implications for disease classification and therapy. *Leuk Res*, 2001. 25(7): p. 571-6.
50. Nagata, H., et al., Identification of a point mutation in the catalytic domain of the protooncogene c-kit in peripheral blood mononuclear cells of patients who have mastocytosis with an associated hematologic disorder. *Proc Natl Acad Sci U S A*, 1995. 92(23): p. 10560-4.
51. Thoren, L.A., et al., Kit regulates maintenance of quiescent hematopoietic stem cells. *J Immunol*, 2008. 180(4): p. 2045-53.
52. Wehrle-Haller, B. and J.A. Weston, Soluble and cell-bound forms of steel factor activity play distinct roles in melanocyte precursor dispersal and survival on the lateral neural crest migration pathway. *Development*, 1995. 121(3): p. 731-42.
53. Hoyer, P.E., A.G. Byskov, and K. Mollgard, Stem cell factor and c-Kit in human primordial germ cells and fetal ovaries. *Mol Cell Endocrinol*, 2005. 234(1-2): p. 1-10.
54. Dolci, S., et al., Requirement for mast cell growth factor for primordial germ cell survival in culture. *Nature*, 1991. 352(6338): p. 809-11.
55. Ray, P., et al., Signaling of c-kit in dendritic cells influences adaptive immunity. *Ann N Y Acad Sci*, 2010. 1183: p. 104-22.

56. Krishnamoorthy, N., et al., Activation of c-Kit in dendritic cells regulates T helper cell differentiation and allergic asthma. *Nat Med*, 2008. 14(5): p. 565-73.
57. Lecoin, L., G. Gabella, and N. Le Douarin, Origin of the c-kit-positive interstitial cells in the avian bowel. *Development*, 1996. 122(3): p. 725-33.
58. Laky, K., L. Lefrancois, and L. Puddington, Age-dependent intestinal lymphoproliferative disorder due to stem cell factor receptor deficiency: parameters in small and large intestine. *J Immunol*, 1997. 158(3): p. 1417-27.
59. Matsui, J., et al., Stem cell factor/c-kit signaling promotes the survival, migration, and capillary tube formation of human umbilical vein endothelial cells. *J Biol Chem*, 2004. 279(18): p. 18600-7.
60. Ding, L., et al., Essential role of stem cell factor-c-Kit signalling pathway in bleomycin-induced pulmonary fibrosis. *J Pathol*, 2013. 230(2): p. 205-14.
61. Lindsey, J.Y., et al., c-Kit is essential for alveolar maintenance and protection from emphysema-like disease in mice. *Am J Respir Crit Care Med*, 2011. 183(12): p. 1644-52.
62. Jin, K., et al., Stem cell factor stimulates neurogenesis in vitro and in vivo. *J Clin Invest*, 2002. 110(3): p. 311-9.
63. Geissler, E.N., M.A. Ryan, and D.E. Housman, The dominant-white spotting (W) locus of the mouse encodes the c-kit proto-oncogene. *Cell*, 1988. 55(1): p. 185-92.
64. Luo, D., et al., Coordinated mRNA expression of c-Kit with tyrosinase and TRP-1 in melanin pigmentation of normal and malignant human melanocytes and transient activation of tyrosinase by Kit/SCF-R. *Melanoma Res*, 1995. 5(5): p. 303-9.
65. Wehrle-Haller, B., The role of Kit-ligand in melanocyte development and epidermal homeostasis. *Pigment Cell Res*, 2003. 16(3): p. 287-96.
66. Wehrle-Haller, B. and J.A. Weston, Receptor tyrosine kinase-dependent neural crest migration in response to differentially localized growth factors. *Bioessays*, 1997. 19(4): p. 337-45.

67. Weston, J.A., Sequential segregation and fate of developmentally restricted intermediate cell populations in the neural crest lineage. *Curr Top Dev Biol*, 1991. 25: p. 133-53.
68. Randall, V.A., et al., Stem cell factor/c-Kit signalling in normal and androgenetic alopecia hair follicles. *J Endocrinol*, 2008. 197(1): p. 11-23.
69. Sharov, A.A., et al., Fas and c-kit are involved in the control of hair follicle melanocyte apoptosis and migration in chemotherapy-induced hair loss. *J Invest Dermatol*, 2003. 120(1): p. 27-35.
70. Kitamura, Y., S. Go, and K. Hatanaka, Decrease of mast cells in W/W^v mice and their increase by bone marrow transplantation. *Blood*, 1978. 52(2): p. 447-52.
71. Iemura, A., et al., The c-kit ligand, stem cell factor, promotes mast cell survival by suppressing apoptosis. *Am J Pathol*, 1994. 144(2): p. 321-8.
72. Rodewald, H.R., et al., Identification of a committed precursor for the mast cell lineage. *Science*, 1996. 271(5250): p. 818-22.
73. Bischoff, S.C. and C.A. Dahinden, c-kit ligand: a unique potentiator of mediator release by human lung mast cells. *J Exp Med*, 1992. 175(1): p. 237-44.
74. Meininger, C.J., et al., The c-kit receptor ligand functions as a mast cell chemoattractant. *Blood*, 1992. 79(4): p. 958-63.
75. Columbo, M., et al., The human recombinant c-kit receptor ligand, rhSCF, induces mediator release from human cutaneous mast cells and enhances IgE-dependent mediator release from both skin mast cells and peripheral blood basophils. *J Immunol*, 1992. 149(2): p. 599-608.
76. Palacios, R. and S. Nishikawa, Developmentally regulated cell surface expression and function of c-kit receptor during lymphocyte ontogeny in the embryo and adult mice. *Development*, 1992. 115(4): p. 1133-47.
77. Geissler, E.N., E.C. McFarland, and E.S. Russell, Analysis of pleiotropism at the dominant white-spotting (W) locus of the house mouse: a description of ten new W alleles. *Genetics*, 1981. 97(2): p. 337-61.

78. Nocka, K., et al., Molecular bases of dominant negative and loss of function mutations at the murine c-kit/white spotting locus: W37, Wv, W41 and W. *EMBO J*, 1990. 9(6): p. 1805-13.
79. Reith, A.D., et al., W mutant mice with mild or severe developmental defects contain distinct point mutations in the kinase domain of the c-kit receptor. *Genes Dev*, 1990. 4(3): p. 390-400.
80. Russell, E.S., et al., Long-continued function of normal blood-forming tissue transplanted into genetically anemic hosts. *J Natl Cancer Inst*, 1959. 23: p. 557-66.
81. McCulloch, E.A., L. Siminovitch, and J.E. Till, Spleen-Colony Formation in Anemic Mice of Genotype Ww. *Science*, 1964. 144(3620): p. 844-6.
82. Lewis, J.P., et al., Growth and differentiation of transplanted W/Wv marrow. *Blood*, 1967. 30(5): p. 601-16.
83. Gregory, C.J. and A.C. Eaves, Three stages of erythropoietic progenitor cell differentiation distinguished by a number of physical and biologic properties. *Blood*, 1978. 51(3): p. 527-37.
84. Barker, J.E., Sl/Sld hematopoietic progenitors are deficient in situ. *Exp Hematol*, 1994. 22(2): p. 174-7.
85. Li, C.L. and G.R. Johnson, Stem cell factor enhances the survival but not the self-renewal of murine hematopoietic long-term repopulating cells. *Blood*, 1994. 84(2): p. 408-14.
86. Leary, A.G., et al., Growth factor requirements for survival in G0 and entry into the cell cycle of primitive human hemopoietic progenitors. *Proc Natl Acad Sci U S A*, 1992. 89(9): p. 4013-7.
87. Bernstein, I.D., R.G. Andrews, and K.M. Zsebo, Recombinant human stem cell factor enhances the formation of colonies by CD34+ and CD34+lin- cells, and the generation of colony-forming cell progeny from CD34+lin- cells cultured with interleukin-3, granulocyte colony-stimulating factor, or granulocyte-macrophage colony-stimulating factor. *Blood*, 1991. 77(11): p. 2316-21.
88. McNiece, I.K., K.E. Langley, and K.M. Zsebo, Recombinant human stem cell factor synergises with GM-CSF, G-CSF, IL-3 and epo to stimulate human

- progenitor cells of the myeloid and erythroid lineages. *Exp Hematol*, 1991. 19(3): p. 226-31.
89. Nocka, K., et al., Candidate ligand for the c-kit transmembrane kinase receptor: KL, a fibroblast derived growth factor stimulates mast cells and erythroid progenitors. *EMBO J*, 1990. 9(10): p. 3287-94.
 90. Kimura, Y., et al., c-Kit-mediated functional positioning of stem cells to their niches is essential for maintenance and regeneration of adult hematopoiesis. *PLoS One*, 2011. 6(10): p. e26918.
 91. Fazel, S.S., et al., Activation of c-kit is necessary for mobilization of reparative bone marrow progenitor cells in response to cardiac injury. *FASEB J*, 2008. 22(3): p. 930-40.
 92. Martin, F.H., et al., Primary structure and functional expression of rat and human stem cell factor DNAs. *Cell*, 1990. 63(1): p. 203-11.
 93. Ropers, H.H. and I.W. Craig, Report of the committee on the genetic constitution of chromosomes 12 and 13. *Cytogenet Cell Genet*, 1989. 51(1-4): p. 259-79.
 94. Anderson, D.M., et al., Alternate splicing of mRNAs encoding human mast cell growth factor and localization of the gene to chromosome 12q22-q24. *Cell Growth Differ*, 1991. 2(8): p. 373-8.
 95. Heissig, B., et al., Recruitment of stem and progenitor cells from the bone marrow niche requires MMP-9 mediated release of kit-ligand. *Cell*, 2002. 109(5): p. 625-37.
 96. Longley, B.J., et al., Chymase cleavage of stem cell factor yields a bioactive, soluble product. *Proc Natl Acad Sci U S A*, 1997. 94(17): p. 9017-21.
 97. Zou, J., et al., Catalytic activity of human ADAM33. *J Biol Chem*, 2004. 279(11): p. 9818-30.
 98. Miyazawa, K., et al., Membrane-bound Steel factor induces more persistent tyrosine kinase activation and longer life span of c-kit gene-encoded protein than its soluble form. *Blood*, 1995. 85(3): p. 641-9.
 99. Ronnstrand, L., Signal transduction via the stem cell factor receptor/c-Kit. *Cell Mol Life Sci*, 2004. 61(19-20): p. 2535-48.

100. Heinrich, M.C., et al., Constitutive expression of steel factor gene by human stromal cells. *Blood*, 1993. 82(3): p. 771-83.
101. Han, Z.B., et al., Hypoxia-inducible factor (HIF)-1 alpha directly enhances the transcriptional activity of stem cell factor (SCF) in response to hypoxia and epidermal growth factor (EGF). *Carcinogenesis*, 2008. 29(10): p. 1853-61.
102. Avraham, H., et al., Effects of the stem cell factor, c-kit ligand, on human megakaryocytic cells. *Blood*, 1992. 79(2): p. 365-71.
103. Hachiya, A., et al., The paracrine role of stem cell factor/c-kit signaling in the activation of human melanocytes in ultraviolet-B-induced pigmentation. *J Invest Dermatol*, 2001. 116(4): p. 578-86.
104. Baba, H., H. Uchiwa, and S. Watanabe, UVB irradiation increases the release of SCF from human epidermal cells. *J Invest Dermatol*, 2005. 124(5): p. 1075-7.
105. Zhang, Z., et al., Crystal structure of human stem cell factor: implication for stem cell factor receptor dimerization and activation. *Proc Natl Acad Sci U S A*, 2000. 97(14): p. 7732-7.
106. Lemmon, M.A. and J. Schlessinger, Cell signaling by receptor tyrosine kinases. *Cell*, 2010. 141(7): p. 1117-34.
107. Yuzawa, S., et al., Structural basis for activation of the receptor tyrosine kinase KIT by stem cell factor. *Cell*, 2007. 130(2): p. 323-34.
108. Mol, C.D., et al., Structural basis for the autoinhibition and STI-571 inhibition of c-Kit tyrosine kinase. *J Biol Chem*, 2004. 279(30): p. 31655-63.
109. Mol, C.D., et al., Structure of a c-kit product complex reveals the basis for kinase transactivation. *J Biol Chem*, 2003. 278(34): p. 31461-4.
110. Masson, K., et al., Direct binding of Cbl to Tyr568 and Tyr936 of the stem cell factor receptor/c-Kit is required for ligand-induced ubiquitination, internalization and degradation. *Biochem J*, 2006. 399(1): p. 59-67.
111. Blume-Jensen, P., R. Janknecht, and T. Hunter, The kit receptor promotes cell survival via activation of PI 3-kinase and subsequent Akt-mediated phosphorylation of Bad on Ser136. *Curr Biol*, 1998. 8(13): p. 779-82.

112. Paulson, R.F., et al., Signalling by the W/Kit receptor tyrosine kinase is negatively regulated in vivo by the protein tyrosine phosphatase Shp1. *Nat Genet*, 1996. 13(3): p. 309-15.
113. Teague, S.J., et al., The Design of Leadlike Combinatorial Libraries. *Angew Chem Int Ed Engl*, 1999. 38(24): p. 3743-3748.
114. Schindler, T., et al., Structural mechanism for STI-571 inhibition of abelson tyrosine kinase. *Science*, 2000. 289(5486): p. 1938-42.
115. Zimmermann, J., et al., Phenylamino-pyrimidine (PAP) derivatives: a new class of potent and selective inhibitors of protein kinase C (PKC). *Arch Pharm (Weinheim)*, 1996. 329(7): p. 371-6.
116. Thommes, K., et al., Identification of Tyr-703 and Tyr-936 as the primary association sites for Grb2 and Grb7 in the c-Kit/stem cell factor receptor. *Biochem J*, 1999. 341 (Pt 1): p. 211-6.
117. Lennartsson, J., et al., Identification of Tyr900 in the kinase domain of c-Kit as a Src-dependent phosphorylation site mediating interaction with c-Crk. *Exp Cell Res*, 2003. 288(1): p. 110-8.
118. Gommerman, J.L., et al., Differential stimulation of c-Kit mutants by membrane-bound and soluble Steel Factor correlates with leukemic potential. *Blood*, 2000. 96(12): p. 3734-42.
119. Krishnan, S., et al., Class I(A) PI3Kinase regulatory subunit, p85alpha, mediates mast cell development through regulation of growth and survival related genes. *PLoS One*, 2012. 7(1): p. e28979.
120. Todd, J.R., et al., The MAPK pathway functions as a redundant survival signal that reinforces the PI3K cascade in c-Kit mutant melanoma. *Oncogene*, 2014. 33(2): p. 236-45.
121. Kirshenbaum, A.S., et al., Demonstration that human mast cells arise from a progenitor cell population that is CD34(+), c-kit(+), and expresses aminopeptidase N (CD13). *Blood*, 1999. 94(7): p. 2333-42.
122. Serve, H., Y.C. Hsu, and P. Besmer, Tyrosine residue 719 of the c-kit receptor is essential for binding of the P85 subunit of phosphatidylinositol (PI) 3-kinase and for c-kit-associated PI 3-kinase activity in COS-1 cells. *J Biol Chem*, 1994. 269(8): p. 6026-30.

123. Lev, S., D. Givol, and Y. Yarden, Interkinase domain of kit contains the binding site for phosphatidylinositol 3' kinase. *Proc Natl Acad Sci U S A*, 1992. 89(2): p. 678-82.
124. Ueda, S., et al., Critical roles of c-Kit tyrosine residues 567 and 719 in stem cell factor-induced chemotaxis: contribution of src family kinase and PI3-kinase on calcium mobilization and cell migration. *Blood*, 2002. 99(9): p. 3342-9.
125. Nishida, K., et al., Requirement of Gab2 for mast cell development and KitL/c-Kit signaling. *Blood*, 2002. 99(5): p. 1866-9.
126. Yu, M., et al., The scaffolding adapter Gab2, via Shp-2, regulates kit-evoked mast cell proliferation by activating the Rac/JNK pathway. *J Biol Chem*, 2006. 281(39): p. 28615-26.
127. Klippel, A., et al., The interaction of small domains between the subunits of phosphatidylinositol 3-kinase determines enzyme activity. *Mol Cell Biol*, 1994. 14(4): p. 2675-85.
128. Alessi, D.R., et al., Characterization of a 3-phosphoinositide-dependent protein kinase which phosphorylates and activates protein kinase Balpha. *Curr Biol*, 1997. 7(4): p. 261-9.
129. Sarbassov, D.D., et al., Phosphorylation and regulation of Akt/PKB by the rictor-mTOR complex. *Science*, 2005. 307(5712): p. 1098-101.
130. Manning, B.D. and L.C. Cantley, AKT/PKB signaling: navigating downstream. *Cell*, 2007. 129(7): p. 1261-74.
131. Yang, E., et al., Bad, a heterodimeric partner for Bcl-XL and Bcl-2, displaces Bax and promotes cell death. *Cell*, 1995. 80(2): p. 285-91.
132. Zha, J., et al., Serine phosphorylation of death agonist BAD in response to survival factor results in binding to 14-3-3 not BCL-X(L). *Cell*, 1996. 87(4): p. 619-28.
133. Brunet, A., et al., Akt promotes cell survival by phosphorylating and inhibiting a Forkhead transcription factor. *Cell*, 1999. 96(6): p. 857-68.

134. Feng, L.X., N. Ravindranath, and M. Dym, Stem cell factor/c-kit up-regulates cyclin D3 and promotes cell cycle progression via the phosphoinositide 3-kinase/p70 S6 kinase pathway in spermatogonia. *J Biol Chem*, 2000. 275(33): p. 25572-6.
135. Kim, M.S., et al., Activation and function of the mTORC1 pathway in mast cells. *J Immunol*, 2008. 180(7): p. 4586-95.
136. Ballif, B.A. and J. Blenis, Molecular mechanisms mediating mammalian mitogen-activated protein kinase (MAPK) kinase (MEK)-MAPK cell survival signals. *Cell Growth Differ*, 2001. 12(8): p. 397-408.
137. Pearson, G., et al., Mitogen-activated protein (MAP) kinase pathways: regulation and physiological functions. *Endocr Rev*, 2001. 22(2): p. 153-83.
138. McDaniel, A.S., et al., Pak1 regulates multiple c-Kit mediated Ras-MAPK gain-in-function phenotypes in *Nf1*^{+/-} mast cells. *Blood*, 2008. 112(12): p. 4646-54.
139. Marschall, J.S., et al., MEK/Erk-based negative feedback mechanism involved in control of Steel Factor-triggered production of Kruppel-like factor 2 in mast cells. *Cell Signal*, 2012. 24(4): p. 879-88.
140. Benson, D.M., Jr., et al., Stem cell factor and interleukin-2/15 combine to enhance MAPK-mediated proliferation of human natural killer cells. *Blood*, 2009. 113(12): p. 2706-14.
141. Lennartsson, J., et al., Phosphorylation of Shc by Src family kinases is necessary for stem cell factor receptor/c-kit mediated activation of the Ras/MAP kinase pathway and c-fos induction. *Oncogene*, 1999. 18(40): p. 5546-53.
142. Simon, C., et al., Lnk adaptor protein down-regulates specific Kit-induced signaling pathways in primary mast cells. *Blood*, 2008. 112(10): p. 4039-47.
143. Du, J., et al., Signaling profiling at the single-cell level identifies a distinct signaling signature in murine hematopoietic stem cells. *Stem Cells*, 2012. 30(7): p. 1447-54.
144. Rodriguez, J., et al., ERK1/2 MAP kinases promote cell cycle entry by rapid, kinase-independent disruption of retinoblastoma-lamin A complexes. *J Cell Biol*, 2010. 191(5): p. 967-79.

145. Pende, M., et al., S6K1(-/-)/S6K2(-/-) mice exhibit perinatal lethality and rapamycin-sensitive 5'-terminal oligopyrimidine mRNA translation and reveal a mitogen-activated protein kinase-dependent S6 kinase pathway. *Mol Cell Biol*, 2004. 24(8): p. 3112-24.
146. Saito, Y., J.R. Vandenheede, and P. Cohen, The mechanism by which epidermal growth factor inhibits glycogen synthase kinase 3 in A431 cells. *Biochem J*, 1994. 303 (Pt 1): p. 27-31.
147. Levy, C., M. Khaled, and D.E. Fisher, MITF: master regulator of melanocyte development and melanoma oncogene. *Trends Mol Med*, 2006. 12(9): p. 406-14.
148. Ryan, T.J., et al., 1999 update: ACC/AHA guidelines for the management of patients with acute myocardial infarction. A report of the American College of Cardiology/American Heart Association Task Force on Practice Guidelines (Committee on Management of Acute Myocardial Infarction). *J Am Coll Cardiol*, 1999. 34(3): p. 890-911.
149. Sutton, M.G. and N. Sharpe, Left ventricular remodeling after myocardial infarction: pathophysiology and therapy. *Circulation*, 2000. 101(25): p. 2981-8.
150. Thomas, S. and M.W. Rich, Epidemiology, pathophysiology, and prognosis of heart failure in the elderly. *Heart Fail Clin*, 2007. 3(4): p. 381-7.
151. Chong, J.J., et al., Human embryonic-stem-cell-derived cardiomyocytes regenerate non-human primate hearts. *Nature*, 2014. 510(7504): p. 273-7.
152. Carpenter, L., et al., Efficient differentiation of human induced pluripotent stem cells generates cardiac cells that provide protection following myocardial infarction in the rat. *Stem Cells Dev*, 2012. 21(6): p. 977-86.
153. Chong, J.J., et al., Adult cardiac-resident MSC-like stem cells with a proepicardial origin. *Cell Stem Cell*, 2011. 9(6): p. 527-40.
154. Sampaolesi, M., et al., Cell therapy of primary myopathies. *Arch Ital Biol*, 2005. 143(3-4): p. 235-42.
155. Makkar, R.R., et al., Intracoronary cardiosphere-derived cells for heart regeneration after myocardial infarction (CADUCEUS): a prospective, randomised phase 1 trial. *Lancet*, 2012. 379(9819): p. 895-904.

156. Chimenti, I., et al., Isolation and expansion of adult cardiac stem/progenitor cells in the form of cardiospheres from human cardiac biopsies and murine hearts. *Methods Mol Biol*, 2012. 879: p. 327-38.
157. Shenje, L.T., et al., Lineage tracing of cardiac explant derived cells. *PLoS One*, 2008. 3(4): p. e1929.
158. Reinecke, H., et al., Survival, integration, and differentiation of cardiomyocyte grafts: a study in normal and injured rat hearts. *Circulation*, 1999. 100(2): p. 193-202.
159. Robey, T.E., et al., Systems approaches to preventing transplanted cell death in cardiac repair. *J Mol Cell Cardiol*, 2008. 45(4): p. 567-81.
160. Schachinger, V., et al., Pilot trial on determinants of progenitor cell recruitment to the infarcted human myocardium. *Circulation*, 2008. 118(14): p. 1425-32.
161. Tang, J., et al., Vascular endothelial growth factor promotes cardiac stem cell migration via the PI3K/Akt pathway. *Exp Cell Res*, 2009. 315(20): p. 3521-31.
162. Tang, J.M., et al., VEGF/SDF-1 promotes cardiac stem cell mobilization and myocardial repair in the infarcted heart. *Cardiovasc Res*, 2011. 91(3): p. 402-11.
163. Mekori, Y.A., C.K. Oh, and D.D. Metcalfe, The role of c-Kit and its ligand, stem cell factor, in mast cell apoptosis. *Int Arch Allergy Immunol*, 1995. 107(1-3): p. 136-8.
164. Pesce, M., A. Di Carlo, and M. De Felici, The c-kit receptor is involved in the adhesion of mouse primordial germ cells to somatic cells in culture. *Mech Dev*, 1997. 68(1-2): p. 37-44.
165. Shin, J.Y., et al., High c-Kit expression identifies hematopoietic stem cells with impaired self-renewal and megakaryocytic bias. *J Exp Med*, 2014. 211(2): p. 217-31.
166. He, J.Q., et al., Human cardiac stem cells isolated from atrial appendages stably express c-kit. *PLoS One*, 2011. 6(11): p. e27719.

167. Wilson, I., et al., One-electron reduction of 2- and 6-methyl-1,4-naphthoquinone bioreductive alkylating agents. *J Med Chem*, 1986. 29(8): p. 1381-4.
168. Cross, C.E., et al., Oxygen radicals and human disease. *Ann Intern Med*, 1987. 107(4): p. 526-45.
169. Soonpaa, M.H. and L.J. Field, Survey of studies examining mammalian cardiomyocyte DNA synthesis. *Circ Res*, 1998. 83(1): p. 15-26.
170. Orth, J.M., et al., Expression of the c-kit gene is critical for migration of neonatal rat gonocytes in vitro. *Biol Reprod*, 1997. 57(3): p. 676-83.
171. Thomson, J.A., et al., Embryonic stem cell lines derived from human blastocysts. *Science*, 1998. 282(5391): p. 1145-7.
172. Xiang, F.L., et al., Cardiomyocyte-specific overexpression of human stem cell factor improves cardiac function and survival after myocardial infarction in mice. *Circulation*, 2009. 120(12): p. 1065-74, 9 p following 1074.
173. Yaniz-Galende, E., et al., Stem cell factor gene transfer promotes cardiac repair after myocardial infarction via in situ recruitment and expansion of c-kit+ cells. *Circ Res*, 2012. 111(11): p. 1434-45.
174. Lowry, P.A., et al., Stem cell factor induction of in vitro murine hematopoietic colony formation by "subliminal" cytokine combinations: the role of "anchor factors". *Blood*, 1992. 80(3): p. 663-9.
175. Gabilove, J.L., et al., Stem cell factor and basic fibroblast growth factor are synergistic in augmenting committed myeloid progenitor cell growth. *Blood*, 1994. 83(4): p. 907-10.
176. Shin, J.S., et al., Serum starvation induces G1 arrest through suppression of Skp2-CDK2 and CDK4 in SK-OV-3 cells. *Int J Oncol*, 2008. 32(2): p. 435-9.
177. Buchkovich, K., L.A. Duffy, and E. Harlow, The retinoblastoma protein is phosphorylated during specific phases of the cell cycle. *Cell*, 1989. 58(6): p. 1097-105.
178. Braun, F., et al., Serum-nutrient starvation induces cell death mediated by Bax and Puma that is counteracted by p21 and unmasked by Bcl-x(L) inhibition. *PLoS One*, 2011. 6(8): p. e23577.

179. Shi, Y., et al., Starvation-induced activation of ATM/Chk2/p53 signaling sensitizes cancer cells to cisplatin. *BMC Cancer*, 2012. 12: p. 571.
180. Zeuner, A., et al., Stem cell factor protects erythroid precursor cells from chemotherapeutic agents via up-regulation of BCL-2 family proteins. *Blood*, 2003. 102(1): p. 87-93.
181. Adams, J.M. and S. Cory, The Bcl-2 apoptotic switch in cancer development and therapy. *Oncogene*, 2007. 26(9): p. 1324-37.
182. Ito, K., et al., Regulation of oxidative stress by ATM is required for self-renewal of haematopoietic stem cells. *Nature*, 2004. 431(7011): p. 997-1002.
183. Tothova, Z., et al., FoxOs are critical mediators of hematopoietic stem cell resistance to physiological oxidative stress. *Cell*, 2007. 128(2): p. 325-39.
184. Ni, Y.G., et al., Foxo transcription factors blunt cardiac hypertrophy by inhibiting calcineurin signaling. *Circulation*, 2006. 114(11): p. 1159-68.
185. Samayawardhena, L.A., et al., Fyn kinase acts upstream of Shp2 and p38 mitogen-activated protein kinase to promote chemotaxis of mast cells towards stem cell factor. *Cell Signal*, 2006. 18(9): p. 1447-54.
186. Linnekin, D., C.S. DeBerry, and S. Mou, Lyn associates with the juxtamembrane region of c-Kit and is activated by stem cell factor in hematopoietic cell lines and normal progenitor cells. *J Biol Chem*, 1997. 272(43): p. 27450-5.
187. Trieselmann, N.Z., J. Soboloff, and S.A. Berger, Mast cells stimulated by membrane-bound, but not soluble, steel factor are dependent on phospholipase C activation. *Cell Mol Life Sci*, 2003. 60(4): p. 759-66.
188. Chian, R., et al., Phosphatidylinositol 3 kinase contributes to the transformation of hematopoietic cells by the D816V c-Kit mutant. *Blood*, 2001. 98(5): p. 1365-73.
189. Rottapel, R., et al., The Steel/W transduction pathway: kit autophosphorylation and its association with a unique subset of cytoplasmic signaling proteins is induced by the Steel factor. *Mol Cell Biol*, 1991. 11(6): p. 3043-51.

190. Herbst, R., S. Munemitsu, and A. Ullrich, Oncogenic activation of v-kit involves deletion of a putative tyrosine-substrate interaction site. *Oncogene*, 1995. 10(2): p. 369-79.
191. Furitsu, T., et al., Identification of mutations in the coding sequence of the proto-oncogene c-kit in a human mast cell leukemia cell line causing ligand-independent activation of c-kit product. *J Clin Invest*, 1993. 92(4): p. 1736-44.
192. Kitayama, H., et al., Constitutively activating mutations of c-kit receptor tyrosine kinase confer factor-independent growth and tumorigenicity of factor-dependent hematopoietic cell lines. *Blood*, 1995. 85(3): p. 790-8.
193. Haas, N., et al., Kit transduced signals counteract erythroid maturation by MAPK-dependent modulation of erythropoietin signaling and apoptosis induction in mouse fetal liver. *Cell Death Differ*, 2014.
194. Jeon, S., et al., Stem cell factor induces ERM proteins phosphorylation through PI3K activation to mediate melanocyte proliferation and migration. *Pigment Cell Melanoma Res*, 2009. 22(1): p. 77-85.
195. Timokhina, I., et al., Kit signaling through PI 3-kinase and Src kinase pathways: an essential role for Rac1 and JNK activation in mast cell proliferation. *EMBO J*, 1998. 17(21): p. 6250-62.
196. Edling, C.E., et al., Haematopoietic progenitor cells utilise conventional PKC to suppress PKB/Akt activity in response to c-Kit stimulation. *Br J Haematol*, 2007. 136(2): p. 260-8.
197. Kuete, V., et al., Pharmacogenomic and molecular docking studies on the cytotoxicity of the natural steroid wortmannin against multidrug-resistant tumor cells. *Phytomedicine*, 2015. 22(1): p. 120-7.
198. Wymann, M.P., et al., Wortmannin inactivates phosphoinositide 3-kinase by covalent modification of Lys-802, a residue involved in the phosphate transfer reaction. *Mol Cell Biol*, 1996. 16(4): p. 1722-33.
199. Roskoski, R., Jr., MEK1/2 dual-specificity protein kinases: structure and regulation. *Biochem Biophys Res Commun*, 2012. 417(1): p. 5-10.
200. Xu, S., et al., Differential regulation of mitogen-activated protein/ERK kinase (MEK)1 and MEK2 and activation by a Ras-independent mechanism. *Mol Endocrinol*, 1997. 11(11): p. 1618-25.

201. Dudley, D.T., et al., A synthetic inhibitor of the mitogen-activated protein kinase cascade. *Proc Natl Acad Sci U S A*, 1995. 92(17): p. 7686-9.
202. Haneline, L.S., et al., Genetic reduction of class IA PI-3 kinase activity alters fetal hematopoiesis and competitive repopulating ability of hematopoietic stem cells in vivo. *Blood*, 2006. 107(4): p. 1375-82.
203. Sui, X., et al., Synergistic activation of MAP kinase (ERK1/2) by erythropoietin and stem cell factor is essential for expanded erythropoiesis. *Blood*, 1998. 92(4): p. 1142-9.
204. Sun, L., J. Lee, and H.A. Fine, Neuronally expressed stem cell factor induces neural stem cell migration to areas of brain injury. *J Clin Invest*, 2004. 113(9): p. 1364-74.
205. Simpson, K., et al., Stem cell factor attenuates liver damage in a murine model of acetaminophen-induced hepatic injury. *Lab Invest*, 2003. 83(2): p. 199-206.
206. Bone-Larson, C.L., et al., Novel protective effects of stem cell factor in a murine model of acute septic peritonitis. Dependence on MCP-1. *Am J Pathol*, 2000. 157(4): p. 1177-86.
207. Fazel, S., et al., Cardioprotective c-kit⁺ cells are from the bone marrow and regulate the myocardial balance of angiogenic cytokines. *J Clin Invest*, 2006. 116(7): p. 1865-77.
208. Wang, C.H., et al., Stem cell factor deficiency is vasculoprotective: unraveling a new therapeutic potential of imatinib mesylate. *Circ Res*, 2006. 99(6): p. 617-25.
209. Frangogiannis, N.G., C.W. Smith, and M.L. Entman, The inflammatory response in myocardial infarction. *Cardiovasc Res*, 2002. 53(1): p. 31-47.
210. Bondzi, C., et al., Src family kinase activity is required for Kit-mediated mitogen-activated protein (MAP) kinase activation, however loss of functional retinoblastoma protein makes MAP kinase activation unnecessary for growth of small cell lung cancer cells. *Cell Growth Differ*, 2000. 11(6): p. 305-14.
211. Lee, Y.N., et al., KIT signaling regulates MITF expression through miRNAs in normal and malignant mast cell proliferation. *Blood*, 2011. 117(13): p. 3629-40.

212. Steingrimsdottir, E., N.G. Copeland, and N.A. Jenkins, Melanocytes and the microphthalmia transcription factor network. *Annu Rev Genet*, 2004. 38: p. 365-411.
213. Klemke, R.L., et al., Regulation of cell motility by mitogen-activated protein kinase. *J Cell Biol*, 1997. 137(2): p. 481-92.
214. Bodemer, C., et al., Pediatric mastocytosis is a clonal disease associated with D816V and other activating c-KIT mutations. *J Invest Dermatol*, 2010. 130(3): p. 804-15.

CURRICULUM VITAE

Bathri Narayan Vajravelu

703 E. Madison St, Apt – A, Louisville, KY 40202
Email: bathrinarayan@gmail.com Phone: 908-787-2039

Education & Training

University of Louisville PhD in Biochemistry & Molecular Genetics	Jul 2010 – Apr 2015
Western Kentucky University Master of Public Health (MPH)	Aug 2008 – May 2010
Tamil Nadu Dr. M.G.R. Medical University, India Bachelor of Medicine, Bachelor of Surgery (MD)	Aug 2000 – May 2006

Awards & Honors

- Integrated Program in Biomedical Sciences Fellowship – 2010-2012
- Outstanding graduate student award in Public Health in 2010, College of Health and Human Services, Western Kentucky University, KY

Patents:

- Inventor of a patent pending interactive teaching and study tool, c-book (Ref: 548/CHE/2013)

Research Experience

Aug 2010 – Apr 2015	PhD Candidate Department of Biochemistry and Molecular Genetics University of Louisville, KY
----------------------------	--

Dissertation Research: Studied the role of c-kit, a type III receptor tyrosine kinase, in the survival, proliferation, migration and differentiation of resident cardiac progenitor cells (CPC). The study aimed at finding ways to increase the survival and migration of cardiac stem cells, which has been previously shown to promote cardiac regeneration in heart disease patients. A part of the study explored the molecular pathways that are activated upon c-kit stimulation

Achievements

- Received training in molecular biology, stem cell biology, regenerative medicine & biochemistry
- Acquainted techniques including, but not limited to, recombinant DNA technology, mechanisms of cell growth/death and differentiation, receptor tyrosine kinase biology, transcriptome profiling, virus-mediated gene delivery, RNAi, immunohistochemistry, Western blot, microscopy, cardiac physiology & histopathology, animal models of myocardial infarction, isolation and characterization of CPCs
- Designed and conducted experiments to explore the role of c-kit, a stem cell marker and a receptor tyrosine kinase in promoting the survival, growth, migration and differentiation of CPCs
- Served an imperative function of culturing and distributing cardiac stem cells in the laboratory. Developed a quantitative RT-PCR assay for assessing cardiac differentiation and to study the mechanisms involved in the differentiation of CPCs
- Ad-hoc reviewer for Research in Veterinary Science, an Elsevier's journal

May 2009 – May 2010

Graduate Assistant – Department of Public Health
Western Kentucky University
Bowling Green, KY

Achievements

- Taught PH-100- Personal Health and PH-365- Human Sexuality (online)
- Analysis of data using SPSS and report writing for Health Education curriculum project and Dental Survey for Barren River District Health Department, Bowling Green
- Proposed a research design for comparing the effectiveness of thrice weekly regimen with daily regimen against pulmonary tuberculosis
- Compiled a portfolio on prevention of HIV infection among international students
- Volunteered and designed a website for Hope Harbor (www.hopeharbor.net)

Clinical Experience

Jun 2006 - Jun 2008 - Attending Physician – Internal Medicine, Dr. R.V.'s Clinic, Tamil Nadu, India

Jun 2007 - Sep 2007 - Fellow in HIV Medicine, Y.R.G. Center for AIDS Research and Education, Tamil Nadu, India

May 2005 - May 2006 - Resident – Internal Medicine and Surgery, Tamil Nadu Dr. M.G.R. Medical University, Tamil Nadu, India

Teaching Experience:

- Student Lecturer, Advanced Biochemistry II (Graduate Level), University of Louisville. Lecture on Serum Lipoproteins and Lipid Transport, Spring 2015
- Teaching Assistant, Advanced Biochemistry II (Graduate Level), University of Louisville. One-on-one teaching to graduate students and graded papers, Spring 2011
- Teaching Assistant, Personal Health (Fall 2009) and Human Sexuality (Spring 2010), Western Kentucky University. Taught the courses online
- Health Educator, Health Curriculum – Future Selves Program, Juvenile Detention Center, Bowling Green, KY. Taught the health curriculum to the inmates, Fall 2010
- Resident – Internal Medicine, Diagnosis and Management of Communicable Diseases, Tamil Nadu Dr. M.G. R. Medical University, India. Lectures to medical students and paramedics, Fall 2005

Volunteer Experience

- Served as a lab manager (2011-2014) in Dr. Kyung Hong's lab at the University of Louisville, KY, managing research projects and research grant
- Served as a student representative in selecting the Biostatistics faculty for the Department of Public Health, May 2009-May 2010, Western Kentucky University
- Served as a health educator for teaching health curriculum at the Juvenile Detention Center through the JDC "Future Selves Program", Fall 2008, Bowling Green, KY
- Served as MPH Coordinator (2009) for the Department of Public Health and played a key role in the recruitment of international students to the MPH program

Publications

Articles

Hong KU, Guo Y, Li Q, Cao P, Al-Maqtari T, **Vajravelu BN**, Du J, Book M, Zhu X, Nong Y, Bhatnagar A, Bolli R. (2014). c-Kit+ Cardiac Stem Cells Alleviate Post-Myocardial Infarction Left Ventricular Dysfunction Despite Poor Engraftment and Negligible Retention in the Recipient Heart; PLOS ONE; May 2014

Keith M, Tang XL, Tokita Y, Li QH, Ghafghazi S, Moore IV J, Hong KU, Elmore B, Amraotkar A, Ganzel BL, Grubb KJ, Flaherty MP, Hunt G, **Vajravelu BN**, Wysoczynski M, Bolli R. (2015) Safety of Intracoronary Infusion of 20 Million c-kit Positive Human Cardiac Stem Cells in Pigs; PLOS ONE; Apr 2015

Submitted for Publication

Vajravelu BN, Hong KU, Al-Maqtari T, Cao P, Keith M, Wysoczynski M, Zhao J, Moore IV J, Bolli R. c-Kit Promotes Cardiac Stem Cell Survival and Migration via the PI3K and the MAPK Pathways (Submitted to AJP-Heart –Feb 2015)

Hong KU, Al-Maqtari T, **Vajravelu BN**, Moktar A, Cao P, Vu D, Bhatnagar A, Bolli R. (2014) Transcription Factor-Induced Activation of Cardiac Gene Expression in c-Kit+ Cardiac Stem cells; The Journal of Biological Chemistry (Manuscript under revision)

Works in Progress

Vajravelu BN, Hong KU, c-Kit – A Receptor Polifacético (Review)

Abstracts

Keith M, Elmore B, Tang XL, Tokita Y, Amraotkar A, Ghafghazi S, Hong KU, **Vajravelu BN**, Wysoczynski M, Moore J, Hunt G, Bolli R (2014) Does the Stop-Flow Technique Improve Cardiac Retention of Intracoronarily Delivered Cells? A Study of Cardiac Retention of C-kit Positive Human Cardiac Stem Cells (hscs) After Intracoronary Infusion in a Porcine Model of Chronic Ischemic Cardiomyopathy; American Heart Association 2014 Scientific Sessions, At Chicago, IL, Volume: 130: A15763

Vajravelu BN, Al-Maqtari T, Moktar A, Cao P, Vu D, Bhatnagar A, Bolli R, Hong K (2014) Stem Cell Factor-Mediated Activation of c-kit Promotes Survival and Migration of Cardiac Stem Cells; Second annual meeting of Kentucky Chapter of the American Physiology Society, Louisville, KY

Al-Maqtari T, **Vajravelu BN**, Mokhtar A, Cao P, Book M, Bhatnagar A, Bolli R, Hong K.U. (2014) Solving the Dilemma of Limited Differentiation of c-kit+ Human Cardiac Stem Cells Used in Heart Repair. Ohio Valley Society of Toxicology Meeting, Dayton, OH

Al-Maqtari T, **Vajravelu BN**, Mokhtar A, Cao P, Book M, Bhatnagar A, Bolli R, Hong K.U. (2014) Gata4 Overexpression to Solve the Dilemma of Limited Differentiation of Human c-kit+ Cardiac Stem Cells Used in Heart Repair. Research Louisville, Louisville, KY

Book M, Al-Maqtari T, **Vajravelu BN**, Cao P, Guo Y, Bolli R, Hong KU (2014) Identification and Isolation of Cardiac Cells Expressing Telomerase. Research Louisville, Louisville, KY

Al-Maqtari T, **Vajravelu BN**, Mokhtar A, Cao P, Bhatnagar A, Hong K, Bolli R (2014) Gata4 Overexpression Facilitates Differentiation of Human Cardiac Stem Cells; Second annual meeting of Kentucky Chapter of the American Physiology Society, Louisville, KY

Vajravelu BN, Al-Maqtari T, Mokhtar A, Cao P, Bhatnagar A, Hong K, Bolli R (2013). Role of c-Kit Signaling in Growth, Migration and Differentiation of Human Cardiac Stem Cells, Proc. The fifth University of Louisville Biochemistry and Molecular Biology Colloquium, Louisville, KY

Vajravelu BN, Al-Maqtari T, Mokhtar A, Cao P, Vu D, Hong K, Bhatnagar A, Bolli R (2013) c-Kit Activation Promotes the Survival, Growth and Migration of Cardiac Stem Cells: Research of Louisville, University of Louisville, School of Medicine, Louisville, KY

Al-Maqtari T, **Vajravelu BN**, Mokhtar A, Cao P, Bhatnagar A, Hong K, Bolli R (2013) Transcription Factor-Induced Activation of Cardiac Gene Expression in c-kit+ Cardiac Stem Cells, American Heart Association (AHA) Scientific Sessions, Dallas, TX

Hong KU, Al-Maqtari T, Mokhtar A, **Vajravelu BN**, Bhatnagar A, Bolli R. (2013) “Directed Differentiation of c-kit+ Human Cardiac Stem Cells in vitro”. American Heart Association (AHA) Basic Cardiovascular Sciences (BCVS) meeting, Las Vegas, NV

Mokhtar A, **Vajravelu BN**, Vu D, Bhatnagar A, Bolli R, Hong KU (2012) Directed Differentiation of c- kit+ Human Cardiac Stem Cells; Research of Louisville, University of Louisville, School of Medicine, Louisville, KY